

70 Draadantennes voor radioamateurs

Iulian Rosu YO3DAC / VA3IUL,

<http://www.qsl.net/va3iul>

ANTENNAS

Summary

1. Tee Antenna	4
2. Half-Lambda Tee Antenna	4
3. Twin-Led Marconi Antenna	5
4. Swallow-Tail Antenna	5
5. Random Length Radiator Wire Antenna	6
6. Windom Antenna	6
7. Windom Antenna - Feed with coax cable	7
8. Quarter Wavelength Vertical Antenna	7
9. Folded Marconi Tee Antenna	8
10. Zeppelin Antenna	8
11. EWE Antenna	9
12. Dipole Antenna - Balun	9
13. Multiband Dipole Antenna	10
14. Inverted-Vee Antenna	10
15. Sloping Dipole Antenna	11
16. Vertical Dipole	12
17. Delta Fed Dipole Antenna	13
18. Bow-Tie Dipole Antenna	13
19. Bow-Tie Dipole Antenna	14
20. Multiband Tuned Doublet Antenna	14
21. G5RV Antenna	15
22. Wideband Dipole Antenna	15
23. Wideband Dipole for Receiving	16
24. Tilted Folded Dipole Antenna	16
25. Right Angle Marconi Antenna	17
26. Linearly Loaded Tee Antenna	17
27. Reduced Size Dipole Antenna	18
28. Doublet Dipole Antenna	18
29. Delta Loop Antenna	19
30. Half Delta Loop Antenna	19
31. Collinear Franklin Antenna	20
32. Four Element Broadside Antenna	20
33. The Lazy-H Array Antenna	21
34. Sterba Curtain Array Antenna	21
35. T-L DX Antenna	22

ANTENNAS

36. 1.9 MHz Full-wave Loop Antenna	23
37. Multi-Band Portable Antenna	24
38. Terminated Sloper Antenna	25
39. Double Extended Zepp Antenna	25
40. TCFTFD Dipole Antenna	26
41. Vee-Sloper Antenna	26
42. Rhombic Inverted-Vee Antenna	27
43. Counterpoise Longwire	27
44. Bisquare Loop Antenna	28
45. Piggyback Antenna for 10m	28
46. Vertical Sleeve Antenna for 10m	29
47. Double Windom Antenna	29
48. Double Windom for 9 Bands	30
49. Collinear Trap Antenna	30
50. Short Dipole Antenna for 40m - 80m - 160m	31
51. Center Fed-Zepp Antenna for 80m - 40m	31
52. All-Bands Antenna	32
53. All-Bands Dipole Antenna	32
54. Multiband Z Antenna	33
55. Multiband Dipole Antenna	33
56. Five-Bands No-Tuner Antenna	33
57. Dualband Full-wave Loop Antenna for 80m-40m	34
58. Loop Antenna for 10m	35
59. Tri-band Delta Loop Antenna for 80m - 40m - 30m	36
60. Dual-band Loop Antenna for 30m - 40m	37
61. Wire-Beam Antenna for 80m	38
62. Dual-Band Sloper Antenna	39
63. Inverted-V Beam Antenna for 30m	40
64. ZL-Special Beam Antenna for 15m	41
65. Half-Sloper Antenna for 160m	41
66. Two-Bands Half Sloper for 80m - 40m	42
67. Linear Loaded Sloper Antenna for 160m	43
68. Super-Sloper Antenna	44
69. Tower Pole as a Vertical Antenna for 80m	44
70. Clothesline Antenna	45

ANTENNAS

1. Tee Antenna

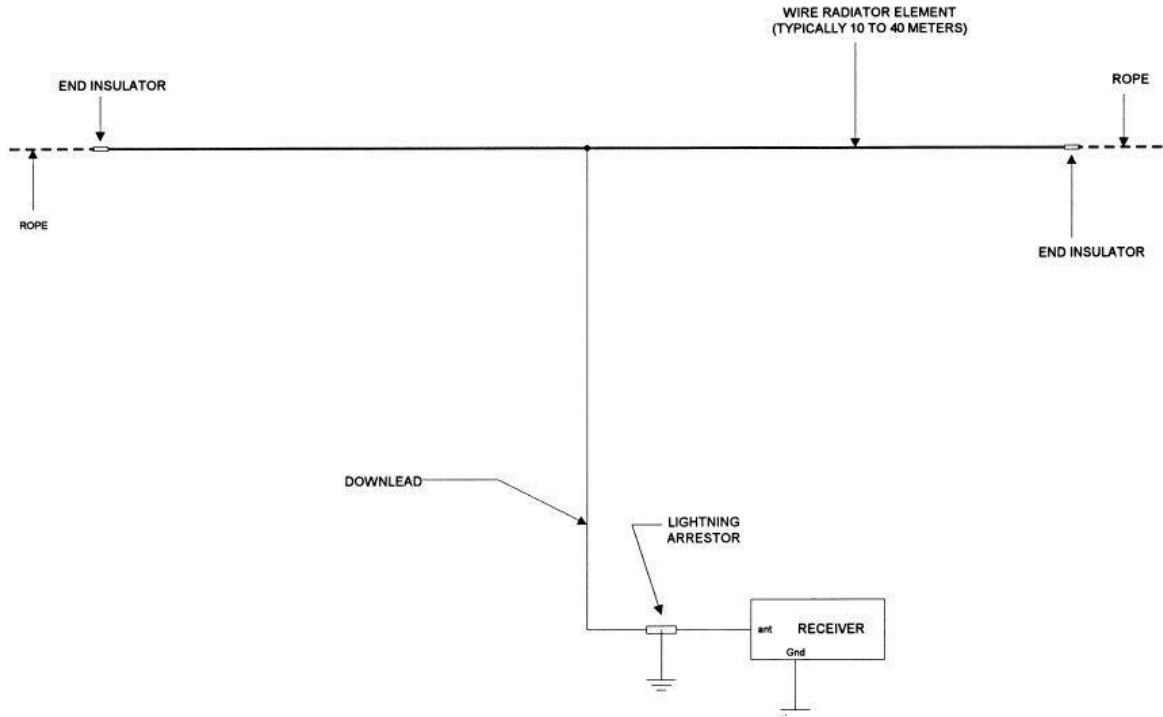

2. Half-Lambda Tee Antenna

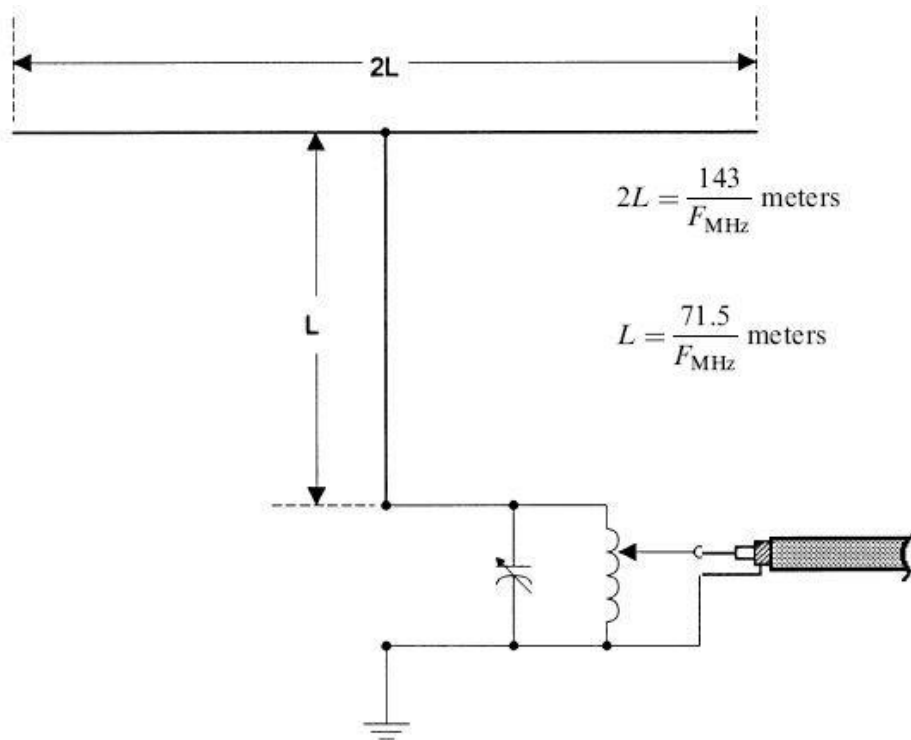

3. Twin-Led Marconi Antenna

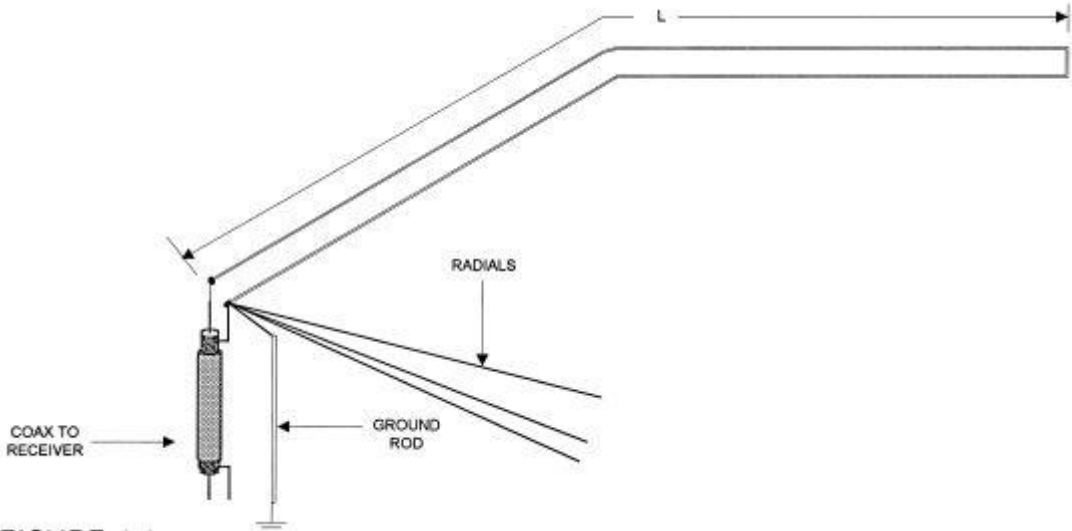

4. Swallow-Tail Antenna

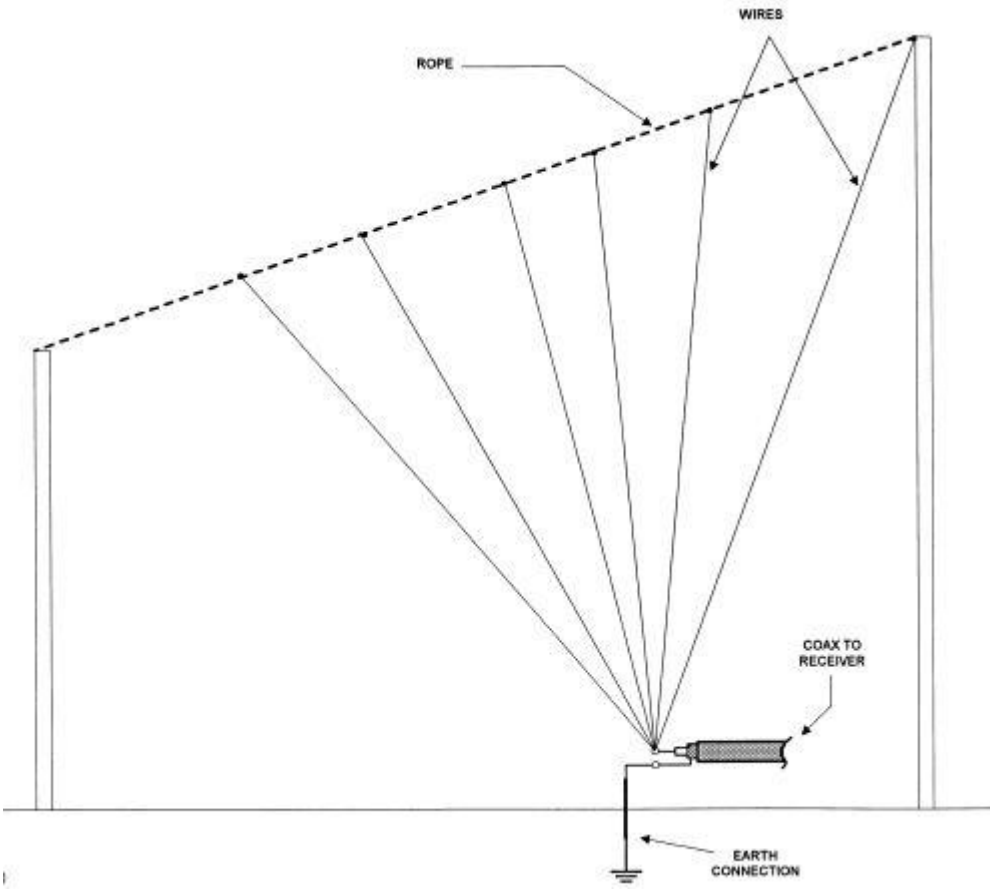

5. Random Length Radiator Wire Antenna

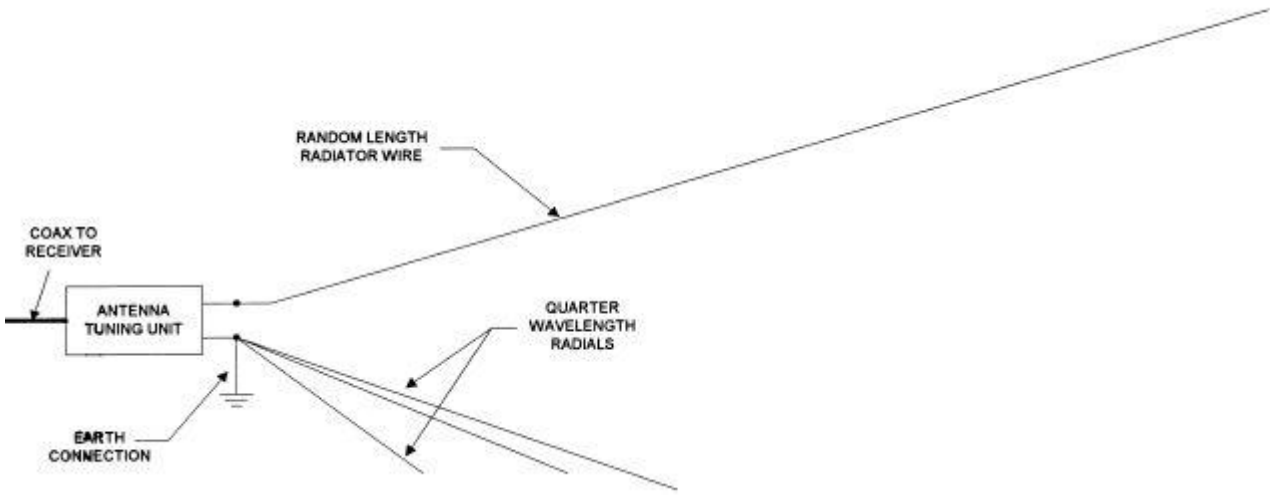

6. Windom Antenna

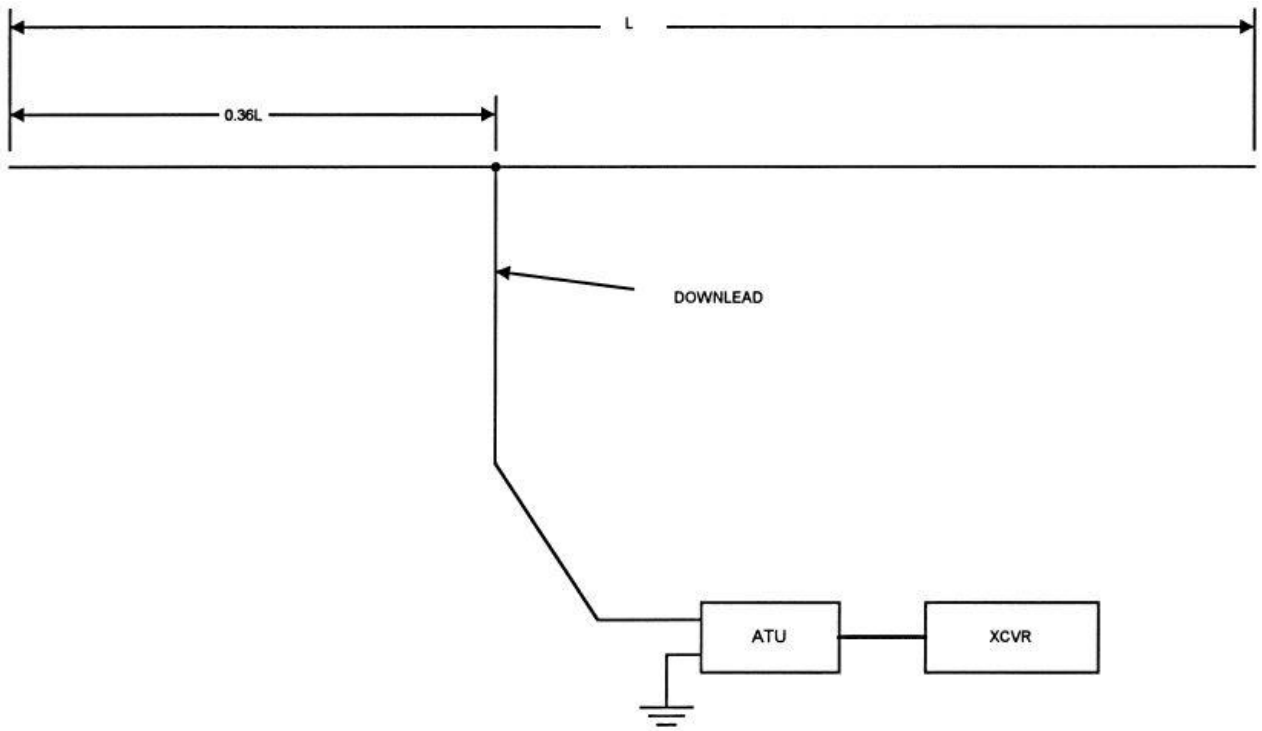

7. Windom Antenna - Feed with coax cable

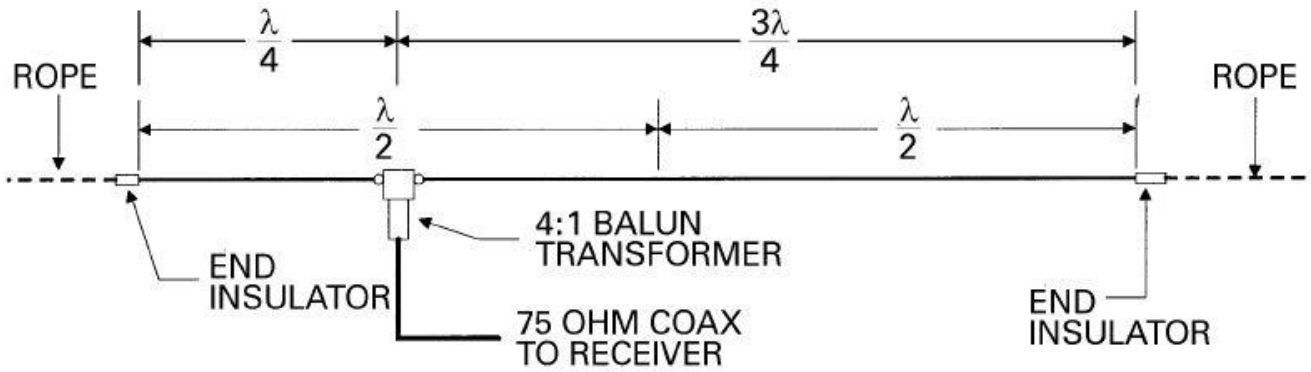

8. Quarter Wavelength Vertical Antenna

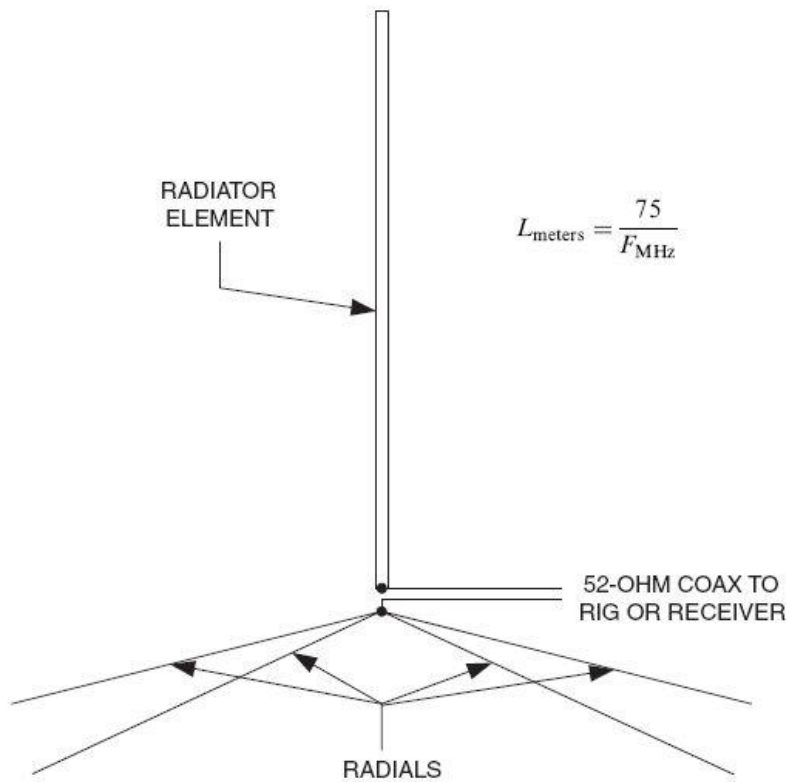

9. Folded Marconi Tee Antenna

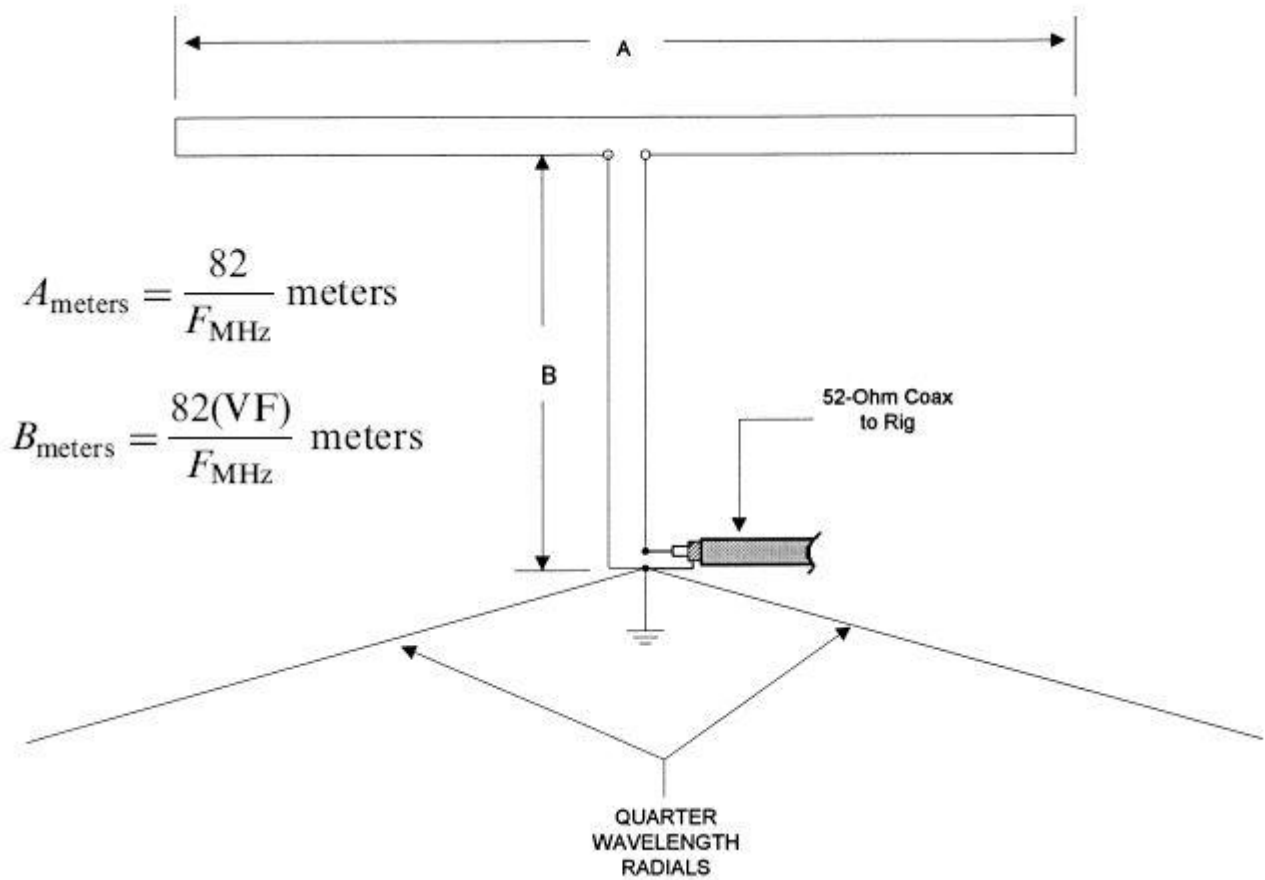

10. Zeppelin Antenna

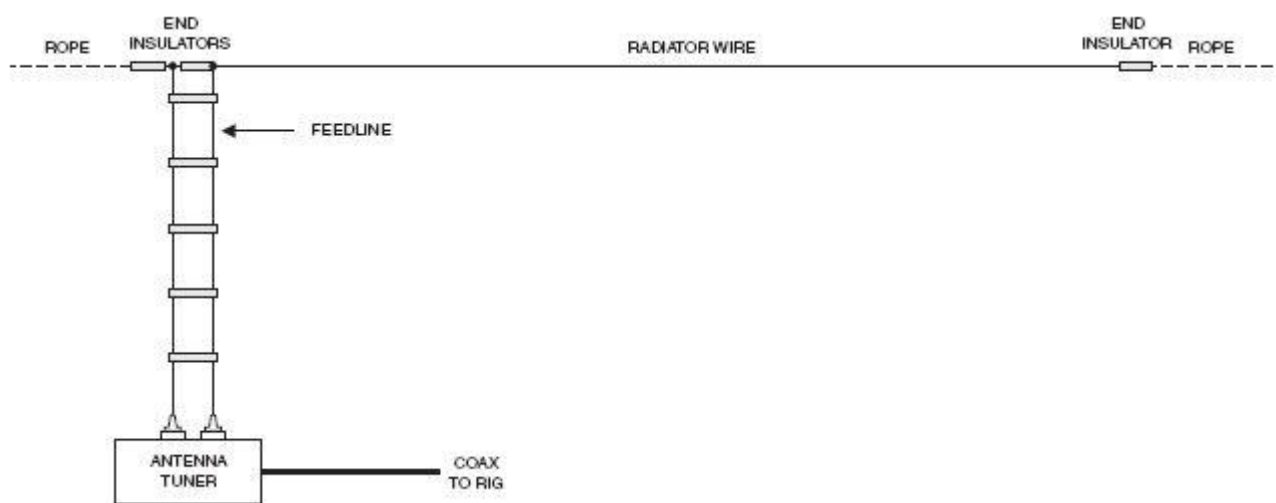

11. EWE Antenna

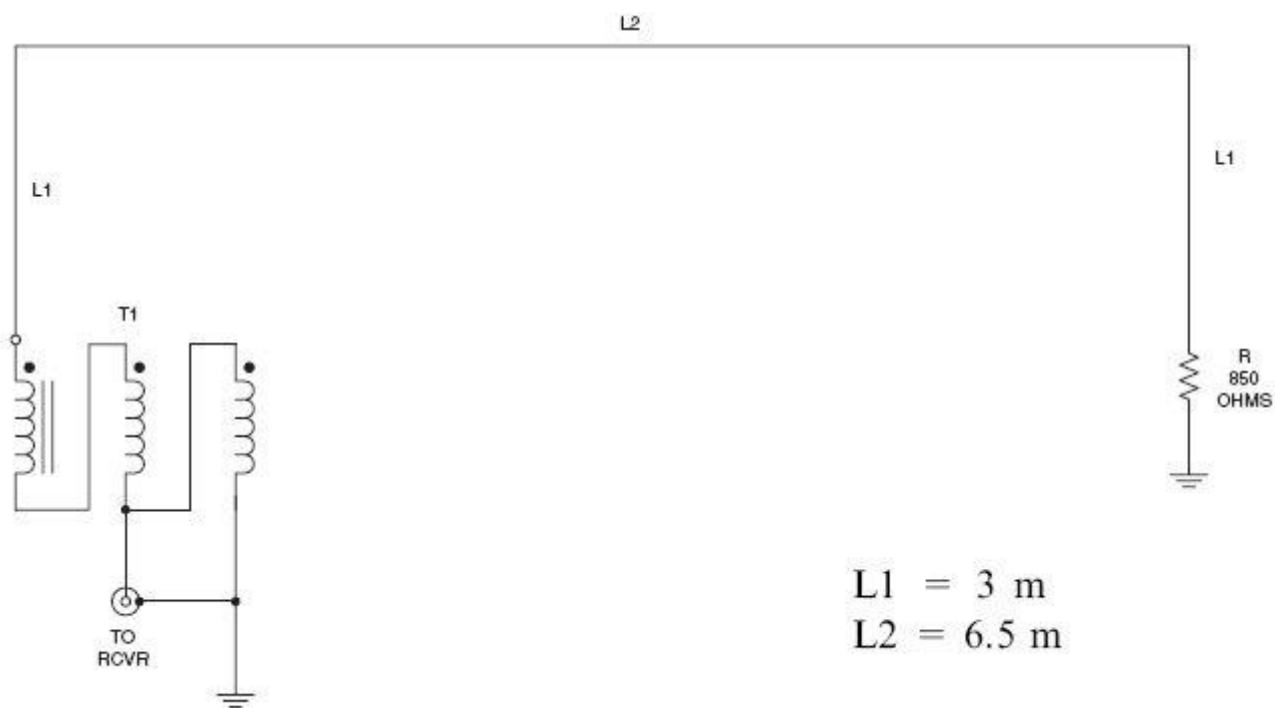

12. Dipole Antenna - Balun

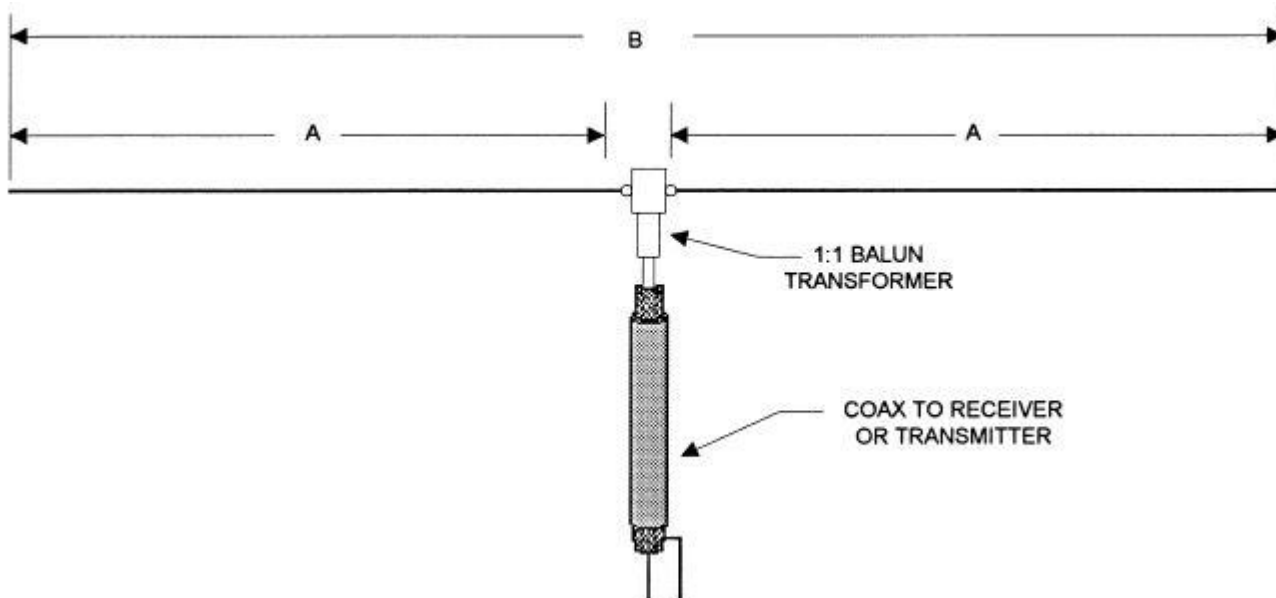

13. Multiband Dipole Antenna

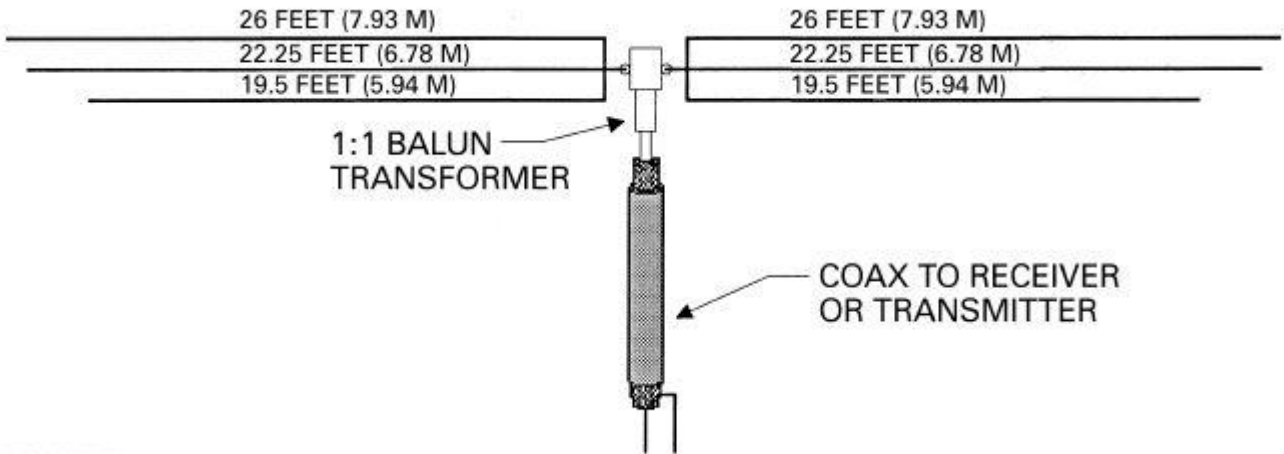

14. Inverted-Vee Antenna

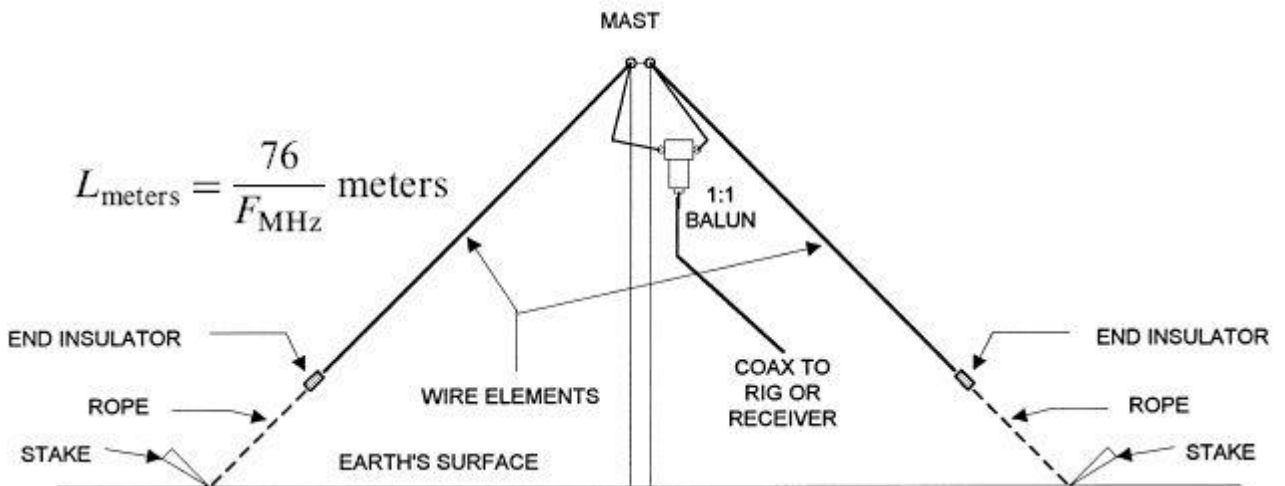

15. Sloping Dipole Antenna

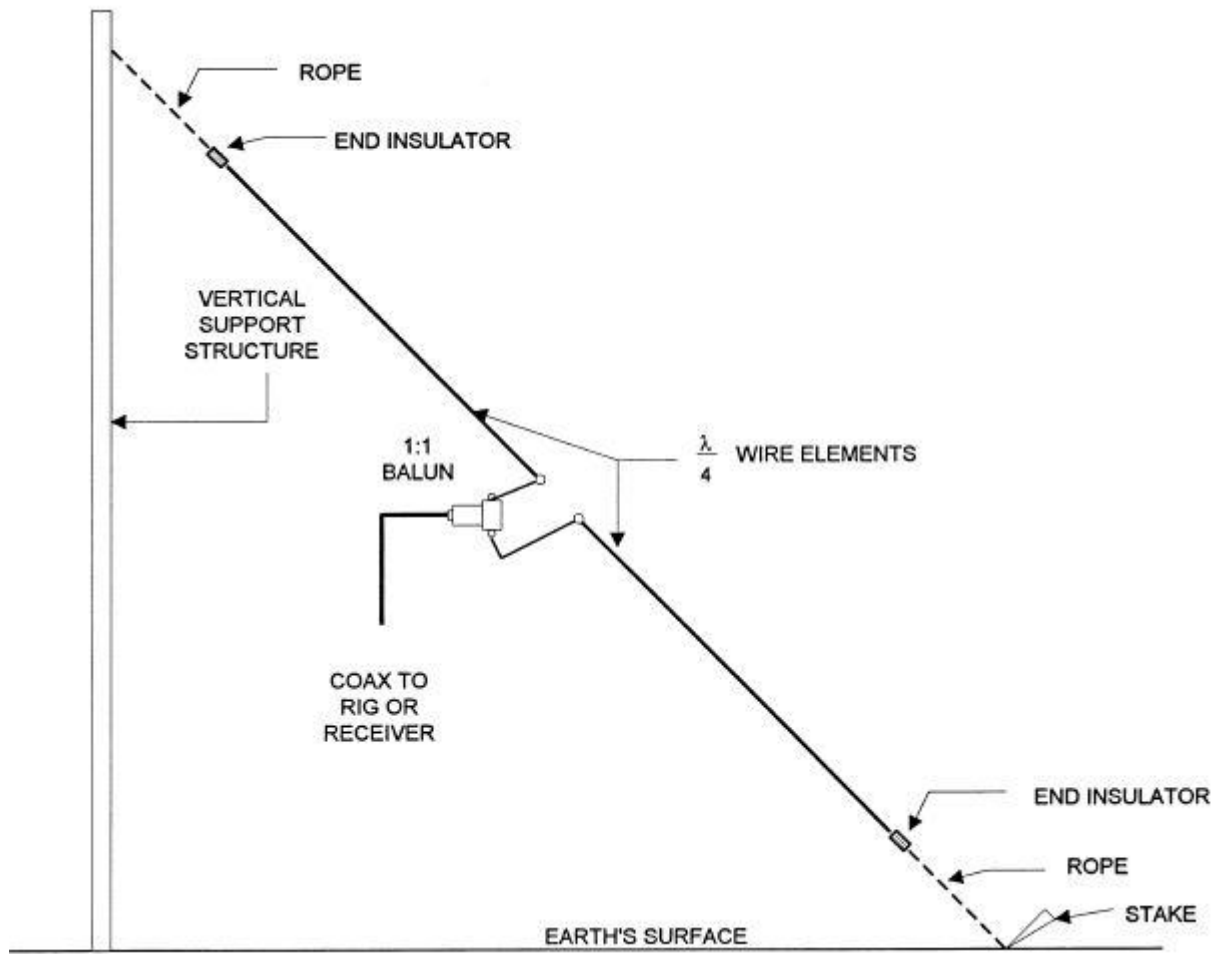

16. Vertical Dipole

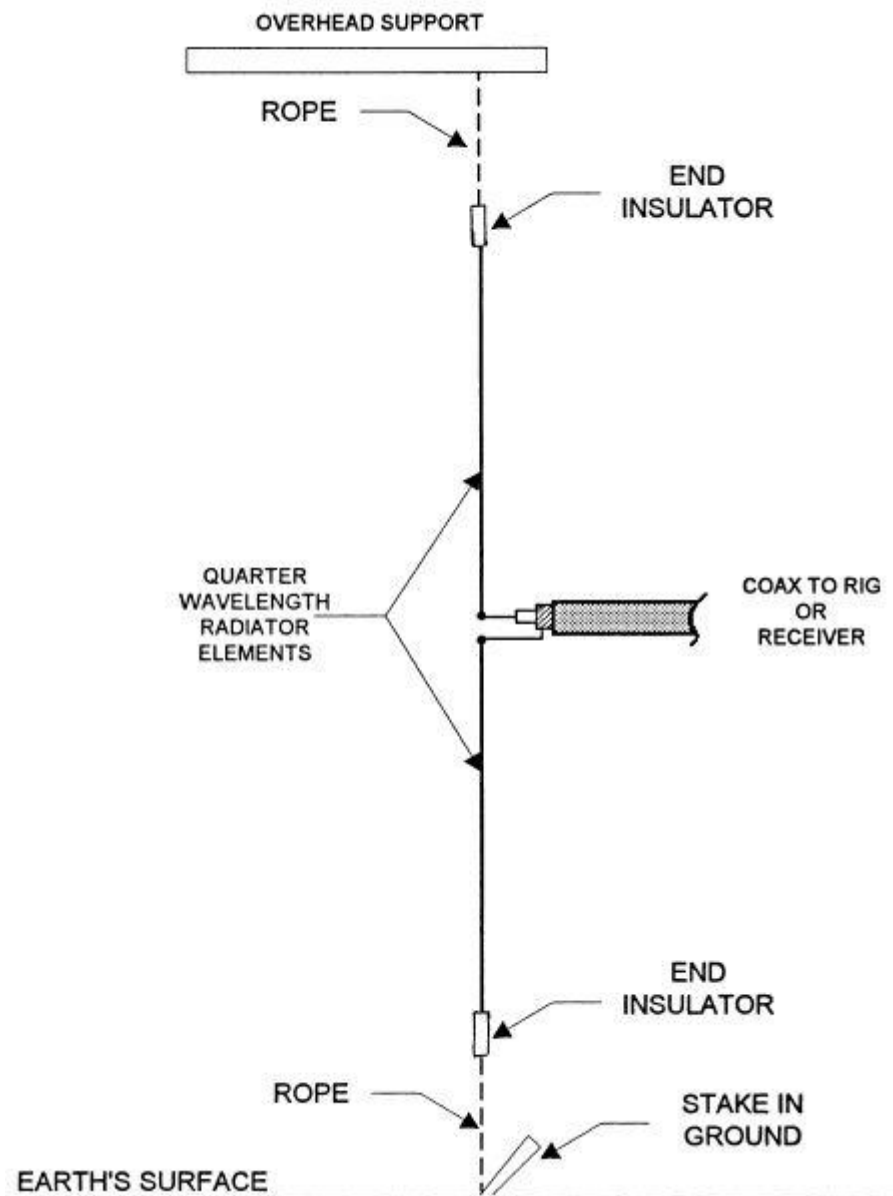

17. Delta Fed Dipole Antenna

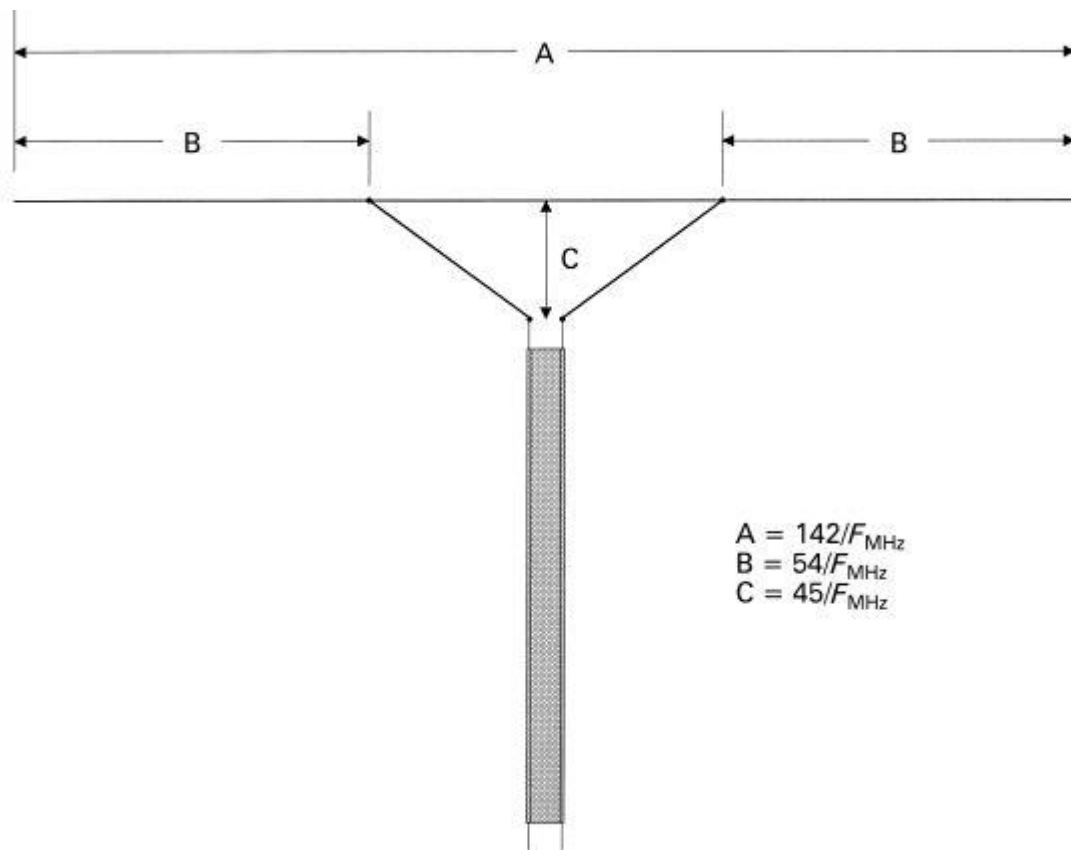

18. Bow-Tie Dipole Antenna

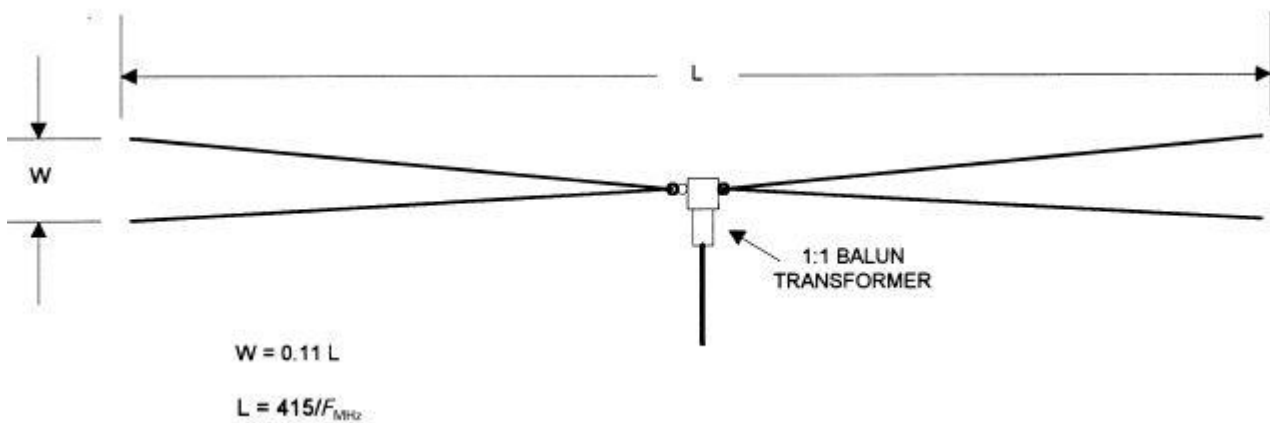

19. Bow-Tie Dipole Antenna

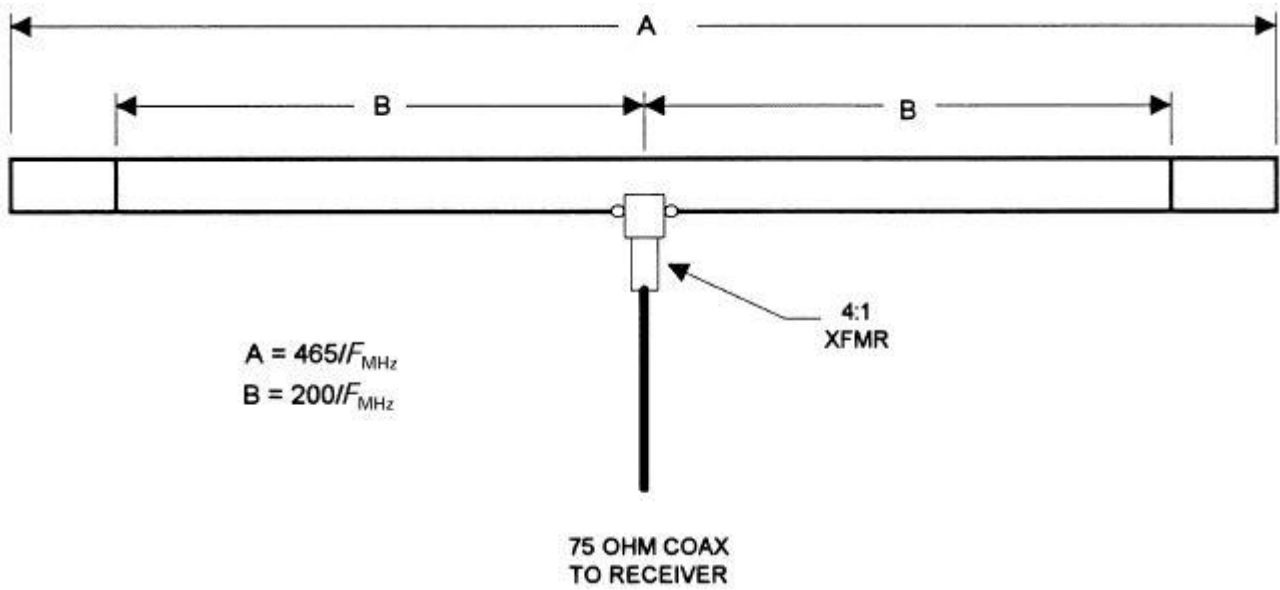

20. Multiband Tuned Doublet Antenna

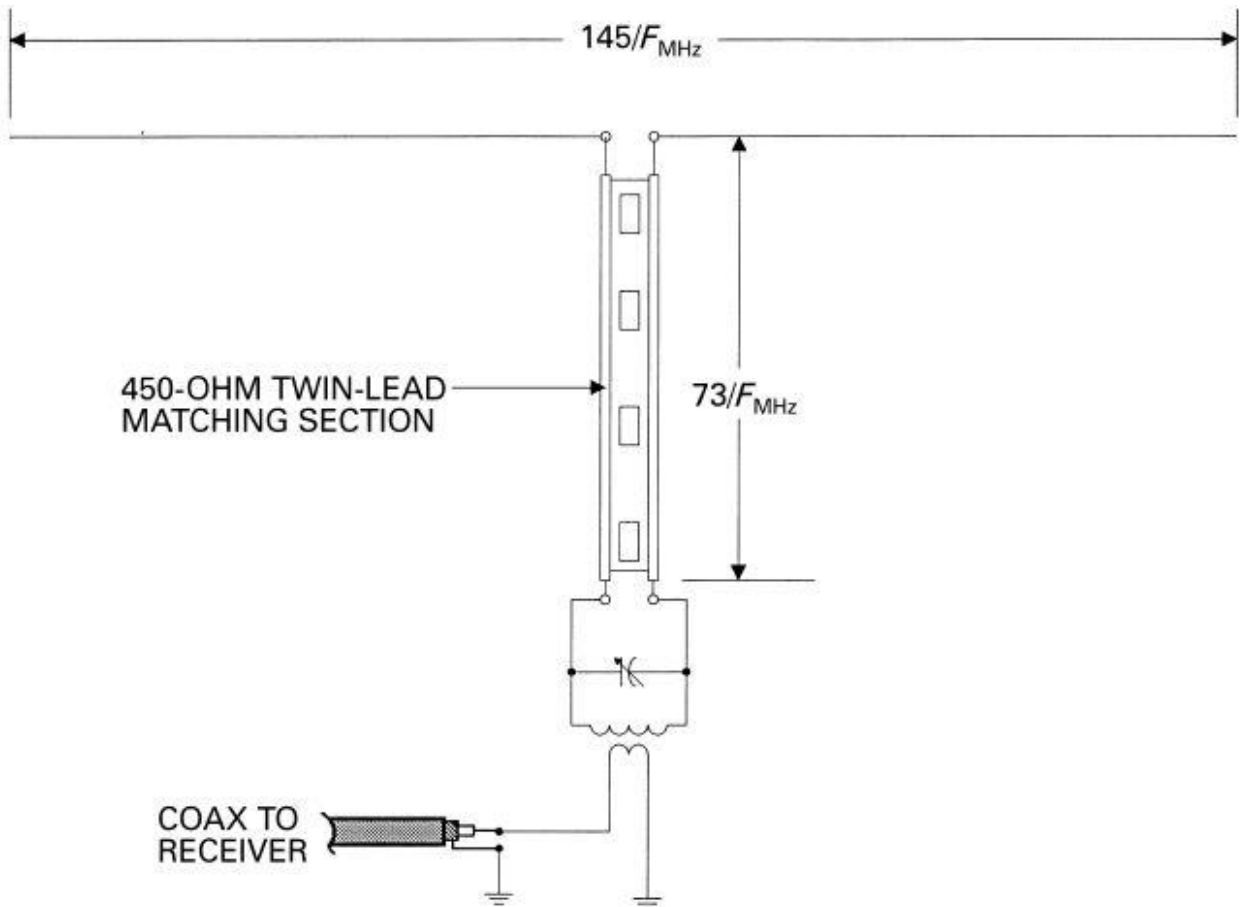

21. G5RV Antenna

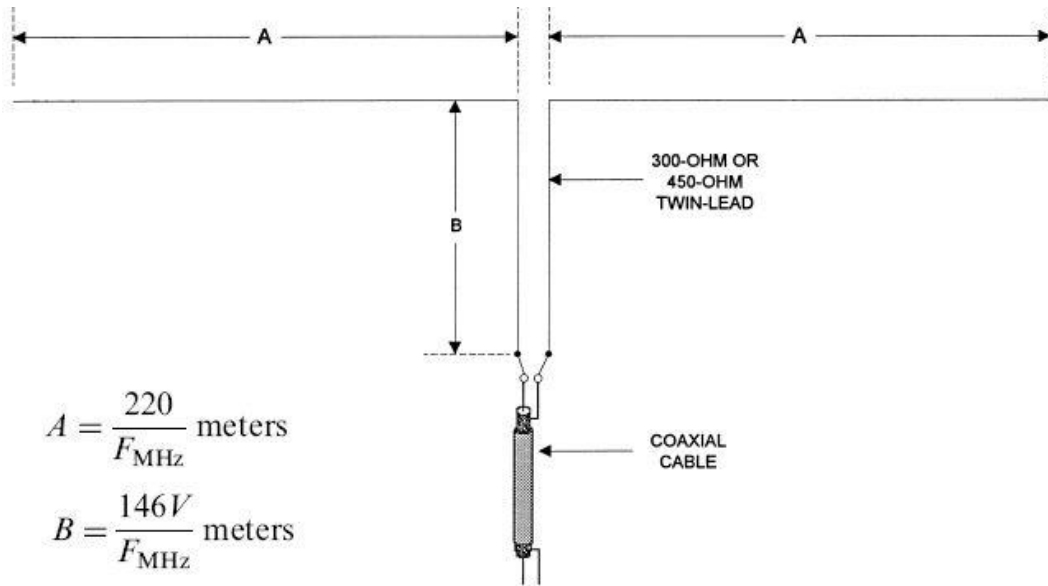

22. Wideband Dipole Antenna

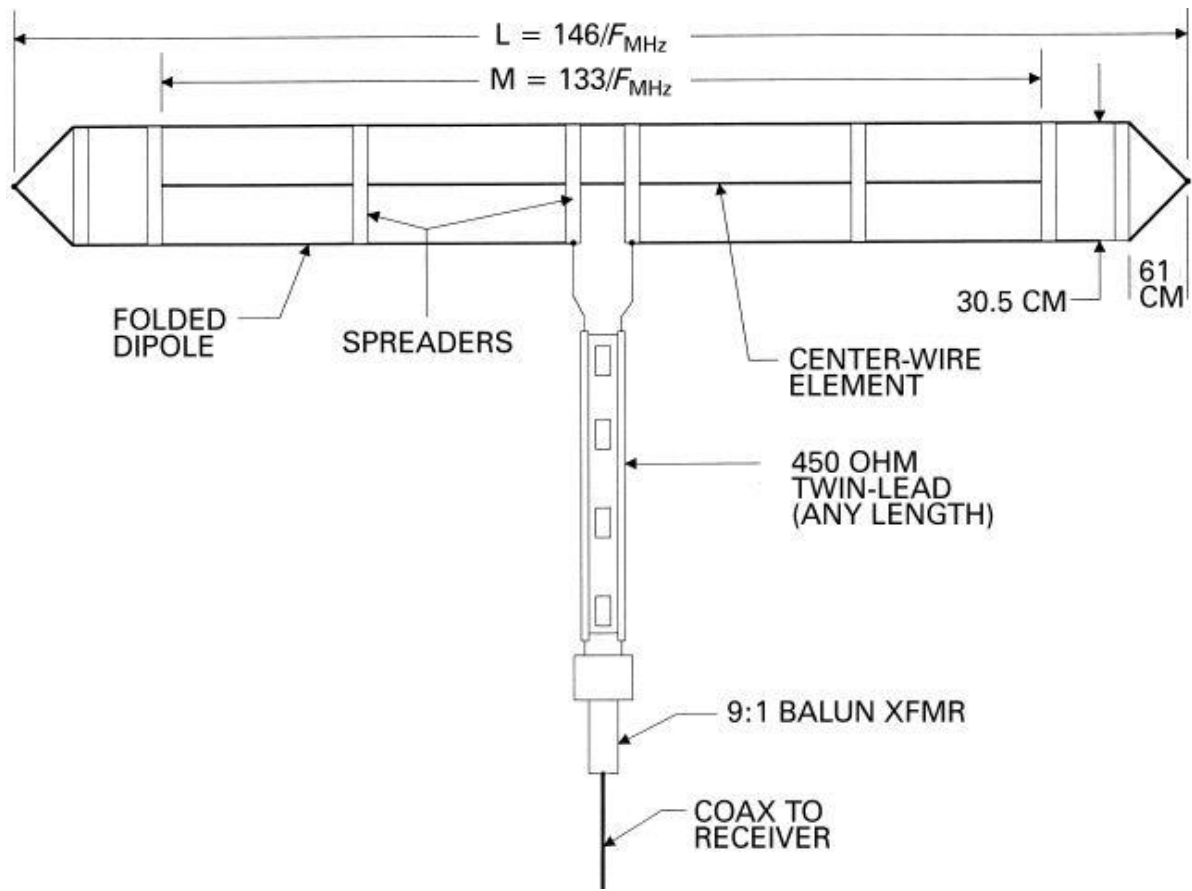

23. Wideband Dipole for Receiving

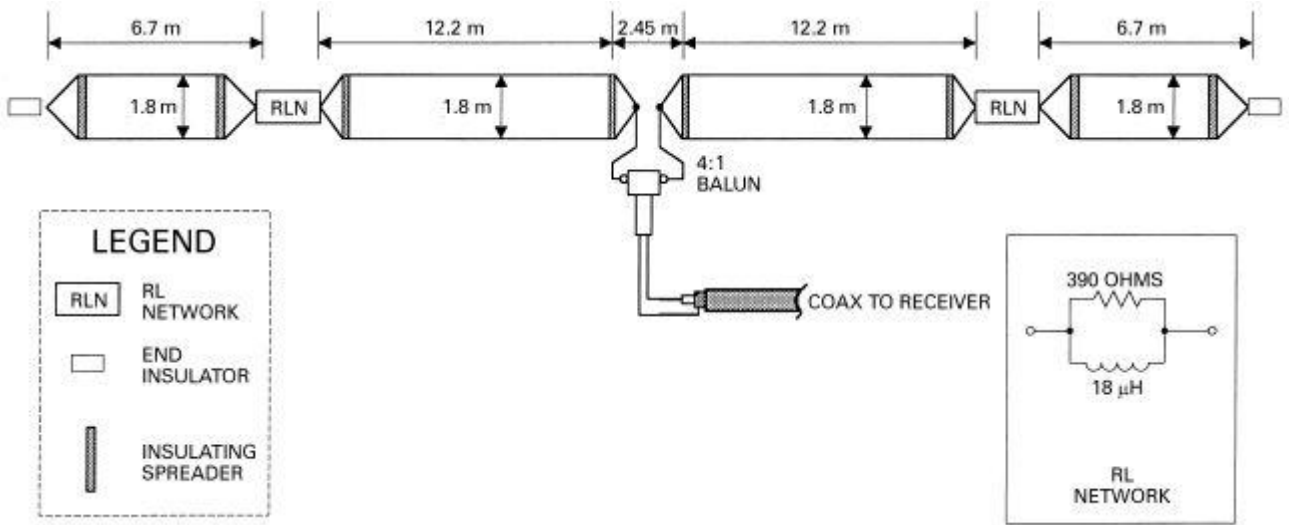

24. Tilted Folded Dipole Antenna

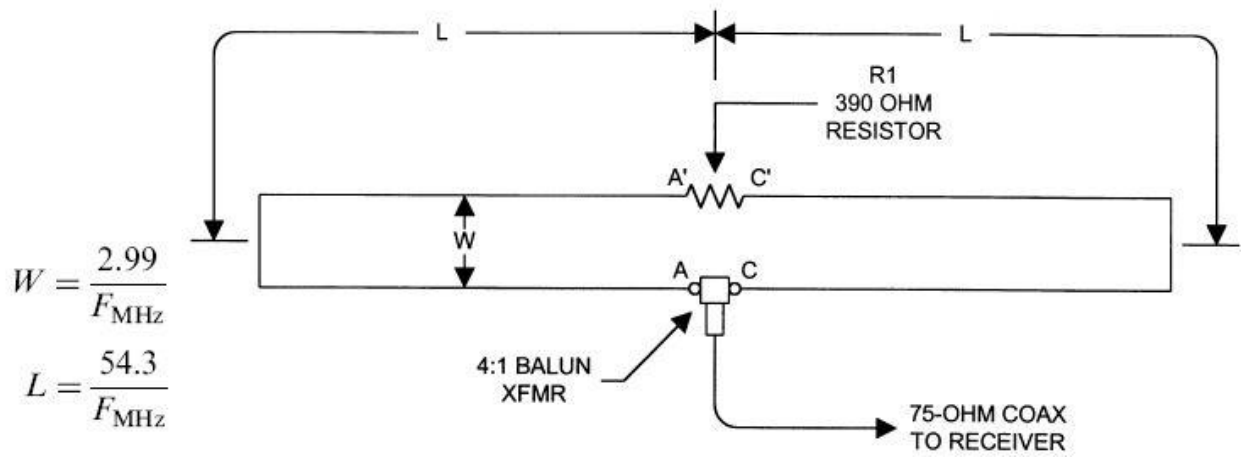

25. Right Angle Marconi Antenna

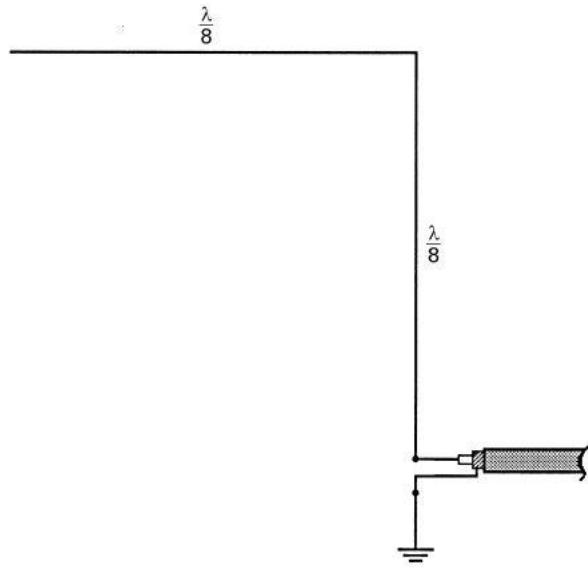

26. Linearly Loaded Tee Antenna

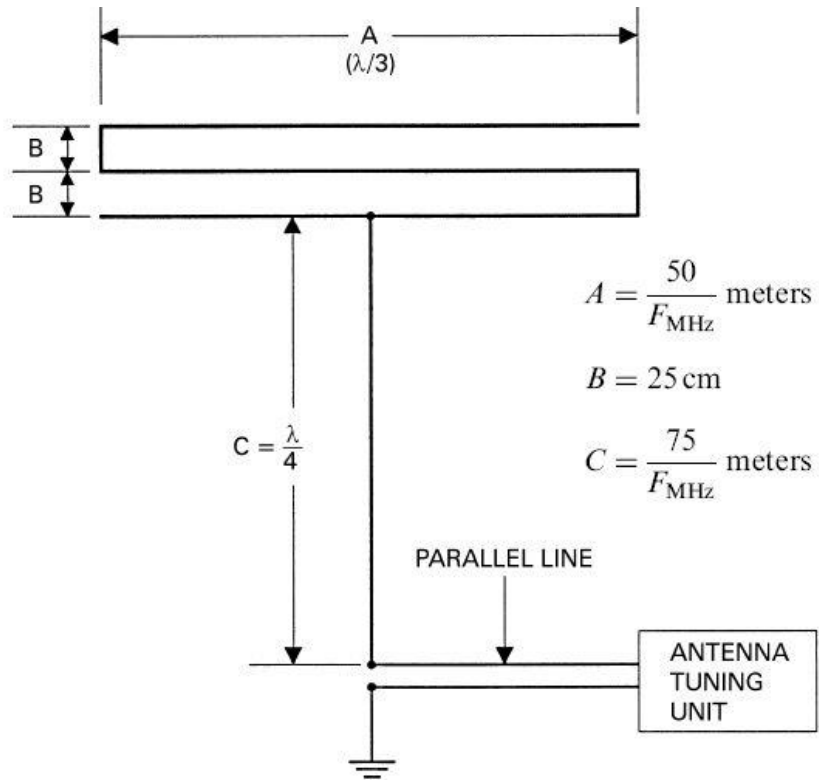

27. **Reduced Size Dipole Antenna**

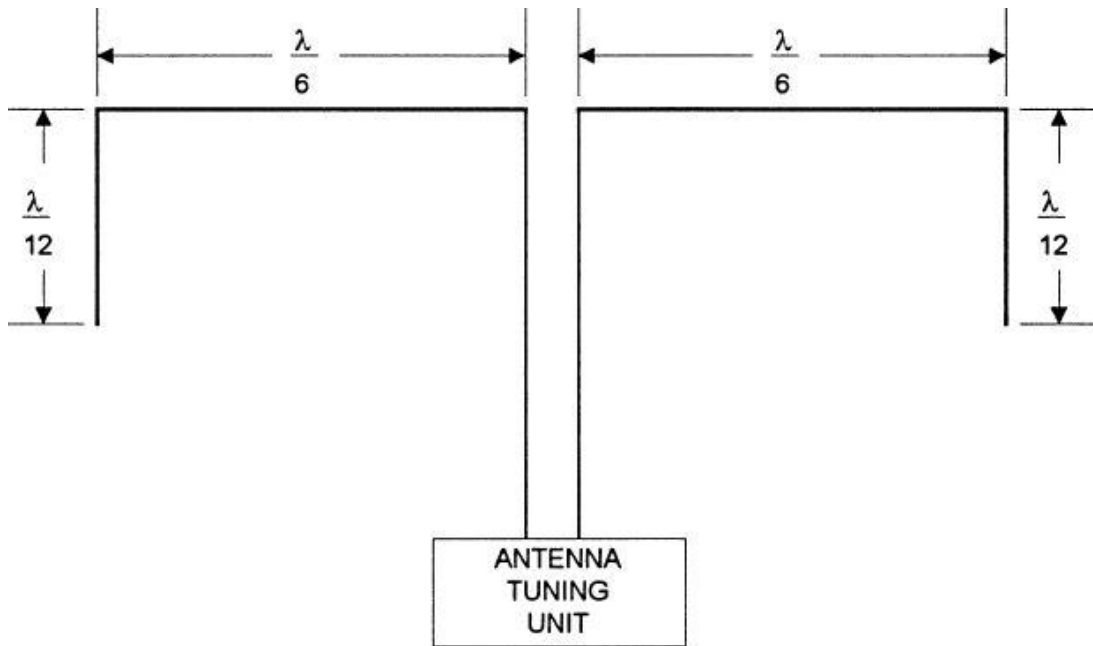

28. **Doublet Dipole Antenna**

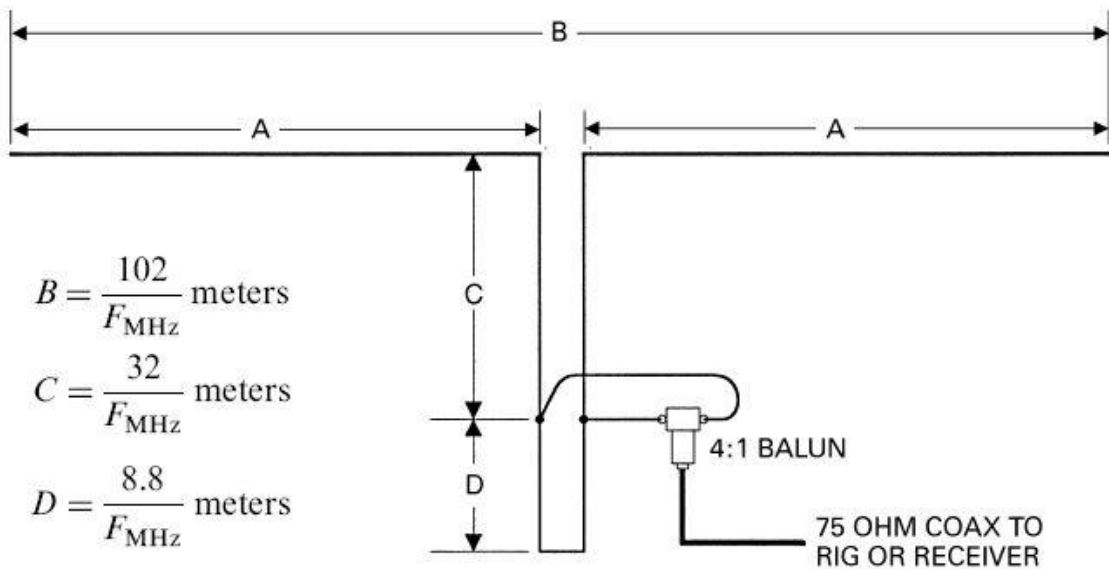

29. Delta Loop Antenna

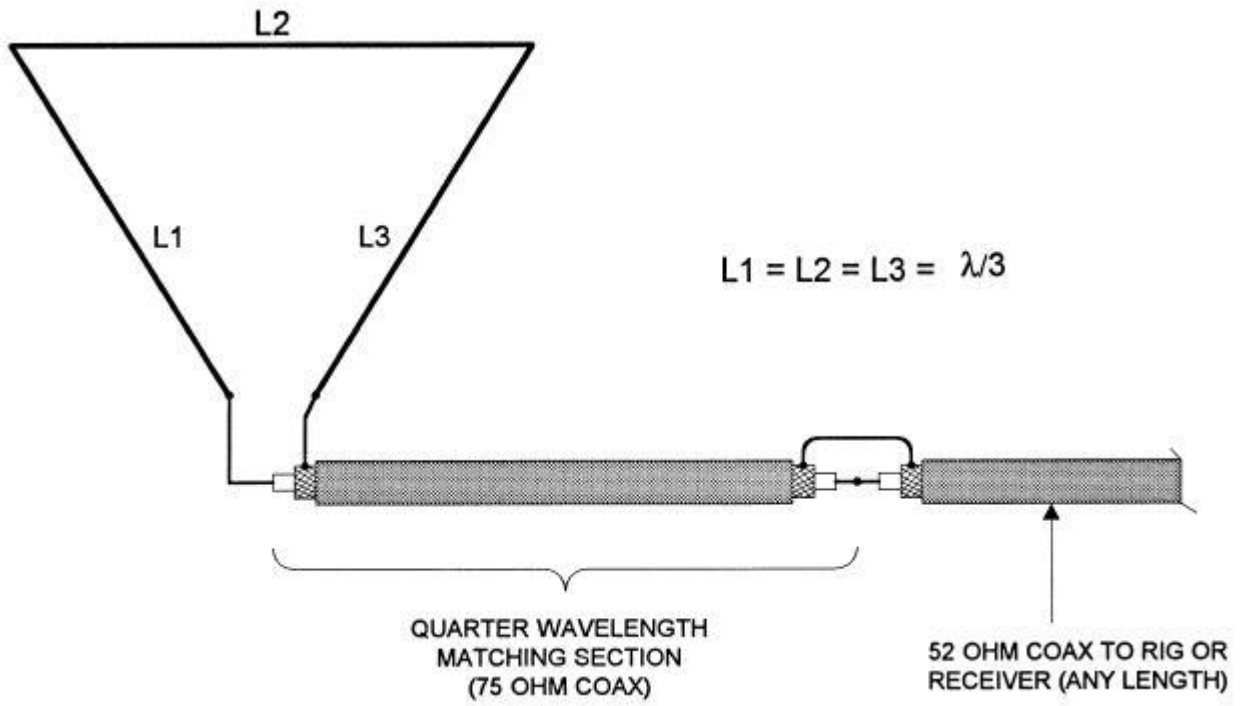

30. Half Delta Loop Antenna

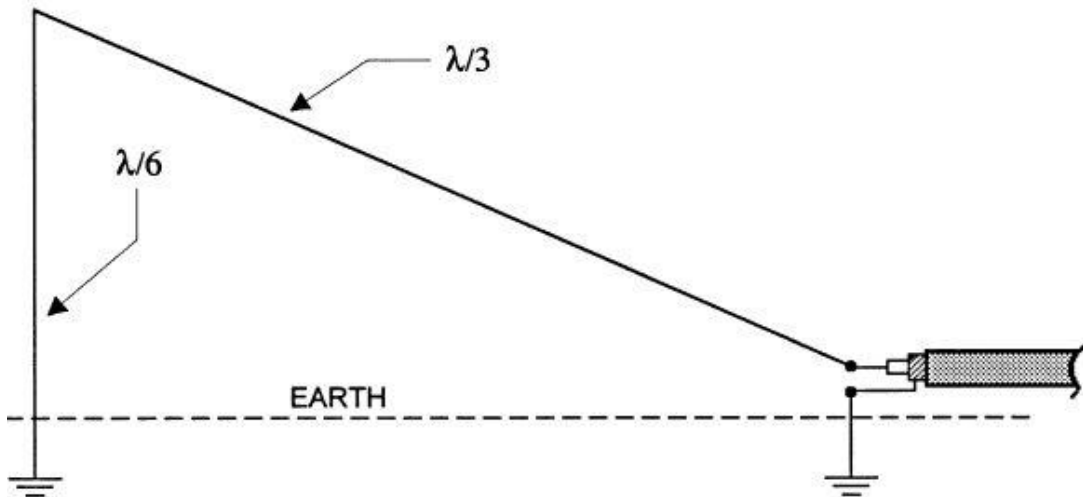

31. Collinear Franklin Antenna

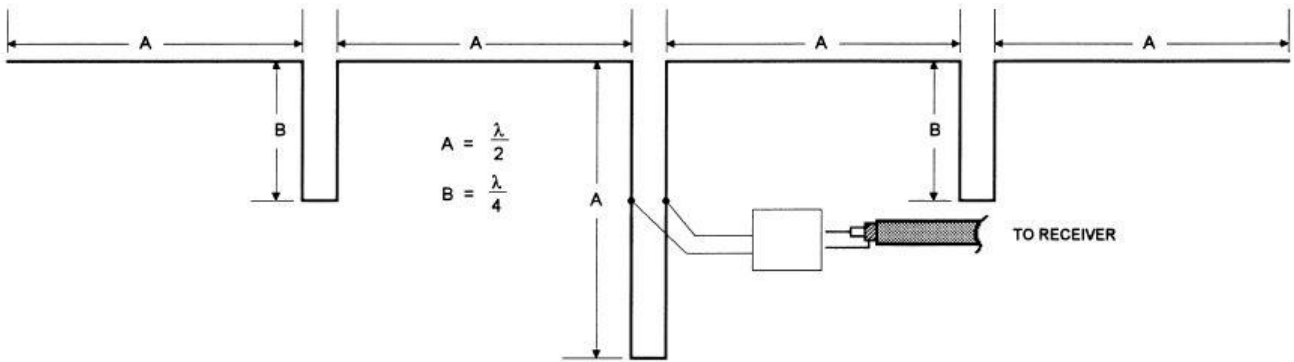

32. Four Element Broadside Antenna

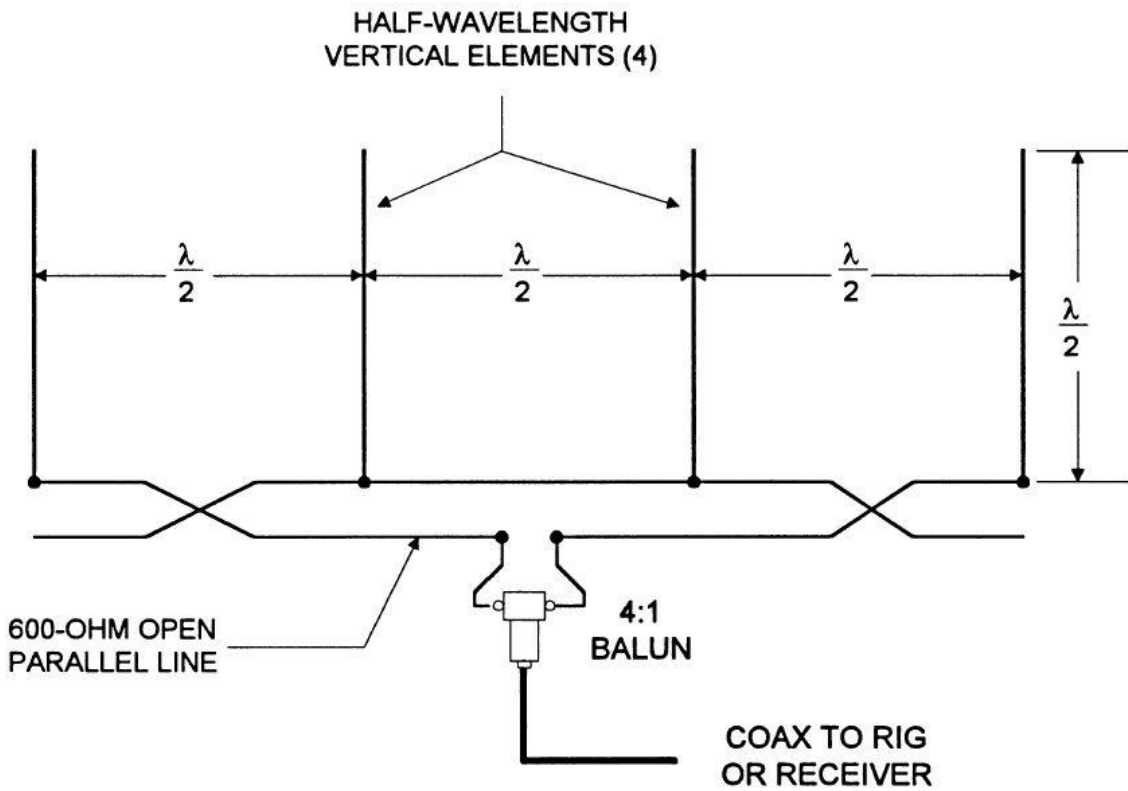

33. The Lazy-H Array Antenna

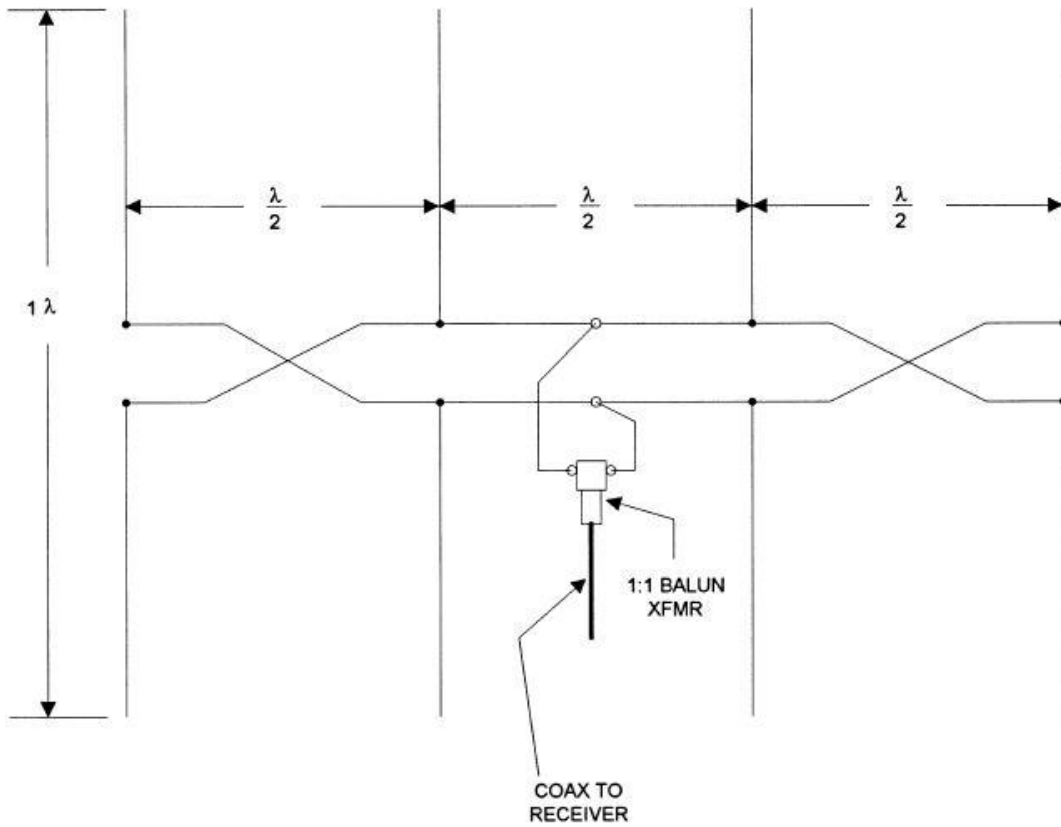

34. Sterba Curtain Array Antenna

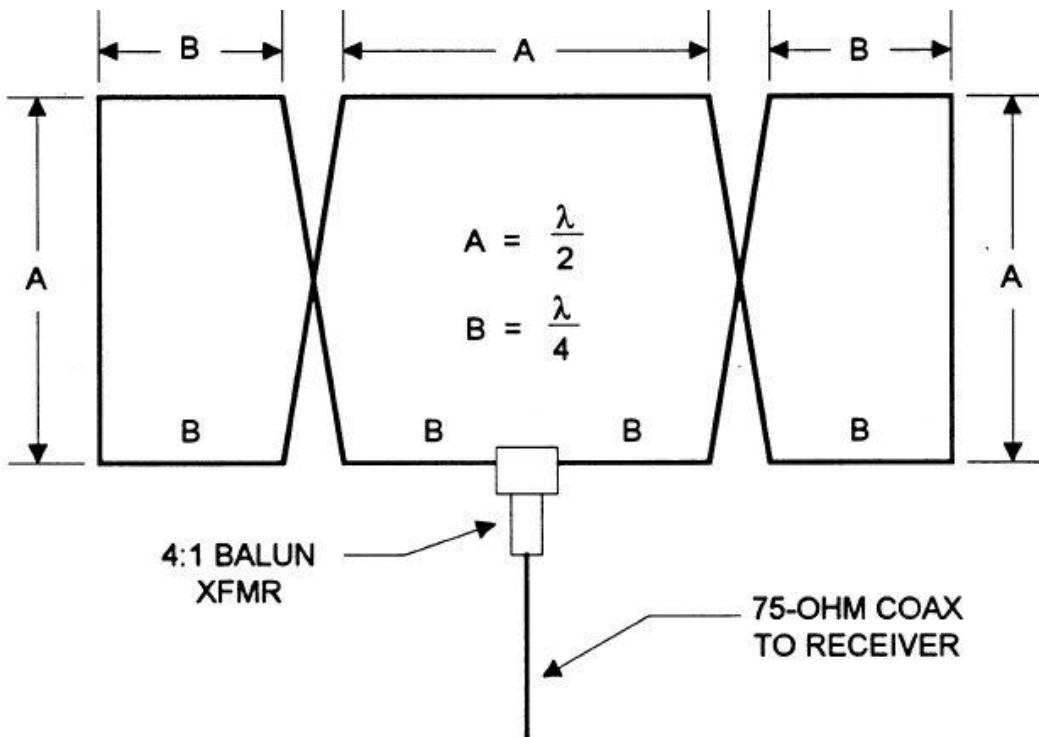

35. T-L DX Antenna

- $L1 = \frac{53.2}{f_{\text{MHz}}}$ meters
- $L2 = \frac{39.8}{f_{\text{MHz}}}$ meters
- $L3 = \frac{66.6}{f_{\text{MHz}}}$ meters
- $L4 = \frac{21.3}{f_{\text{MHz}}}$ meters
- $L5 = \frac{108.4}{f_{\text{MHz}}}$ meters
- $L6 = \frac{94.2}{f_{\text{MHz}}}$ meters
- $L7 = \frac{136.8}{f_{\text{MHz}}}$ meters

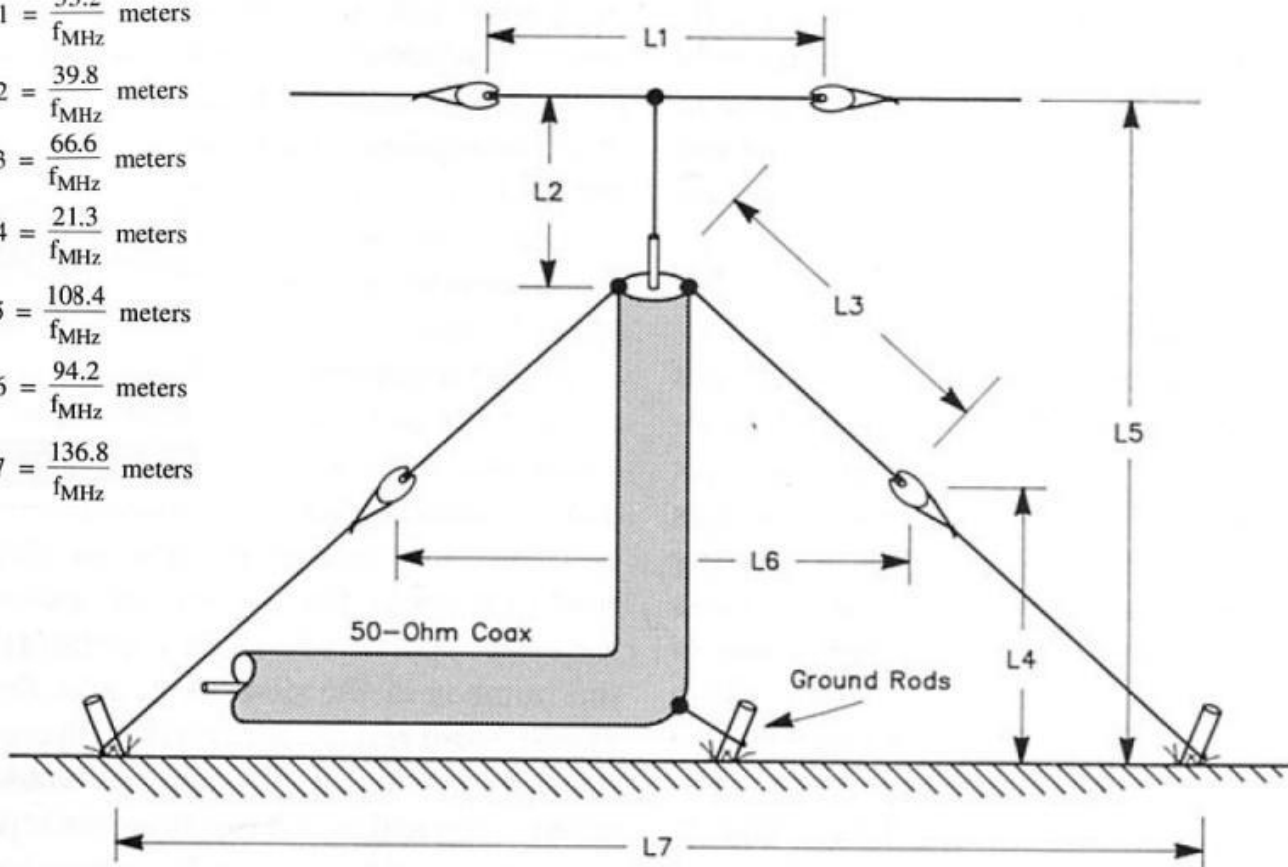

36. 1.9 MHz Full-wave Loop Antenna

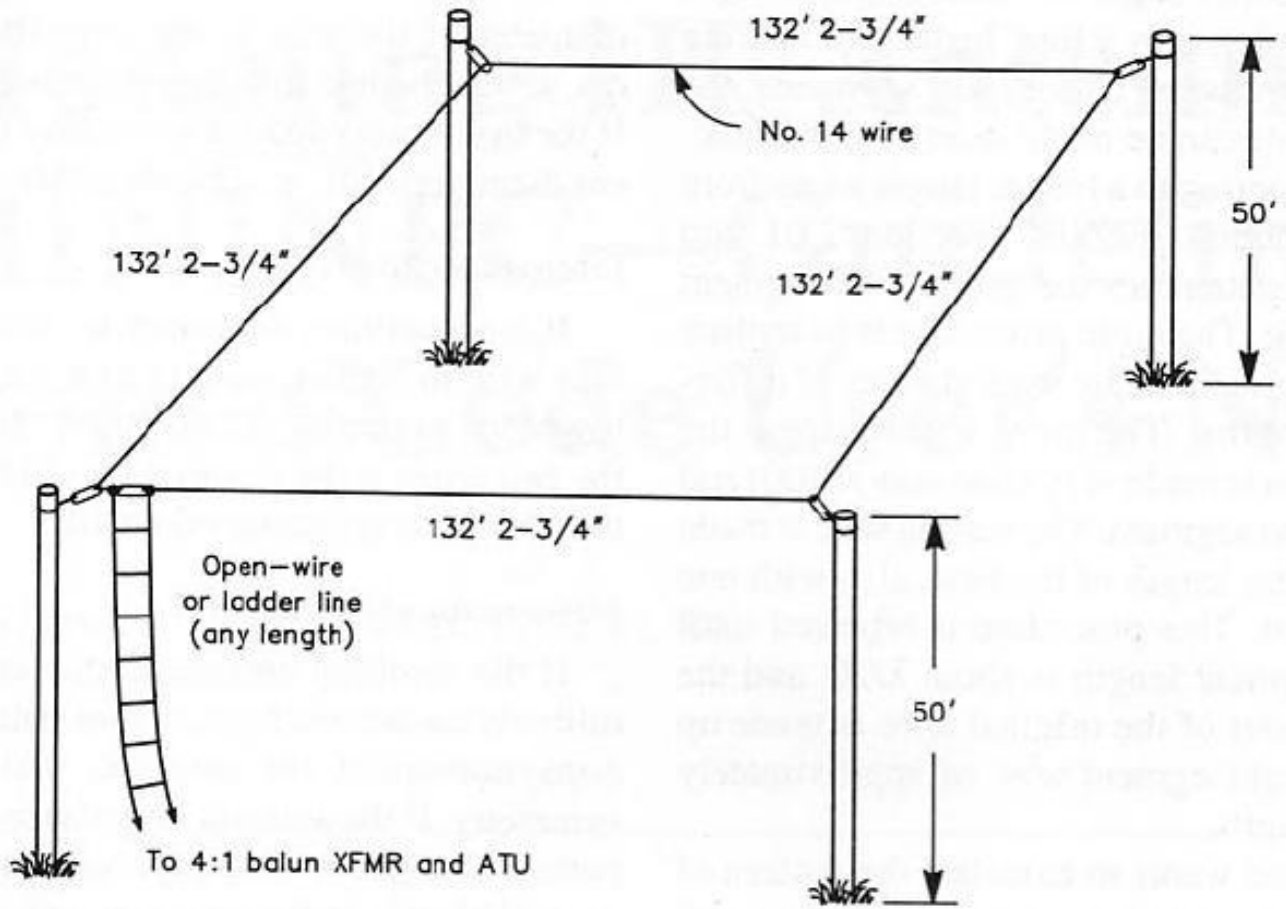

37. Multi-Band Portable Antenna

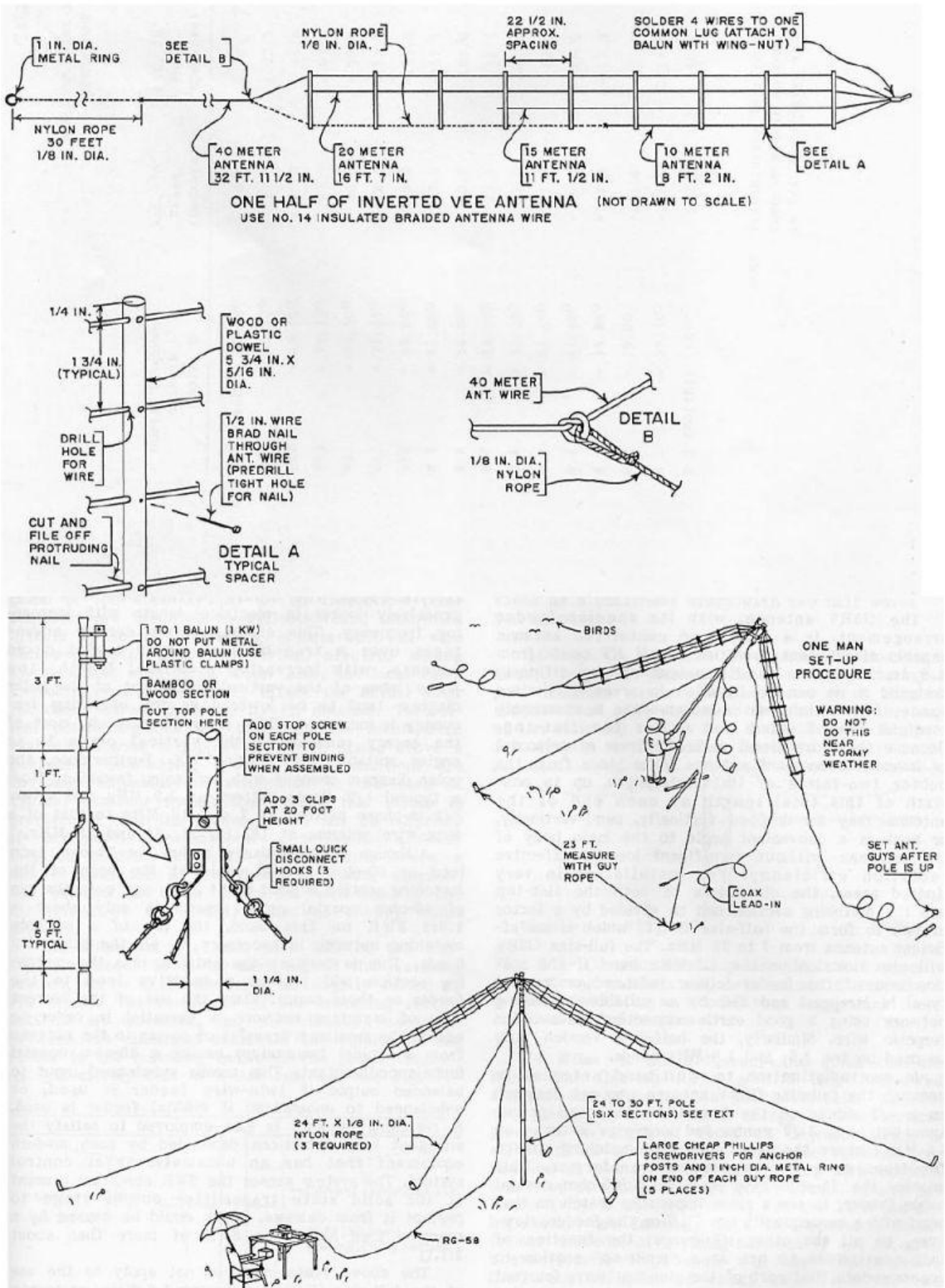

38. Terminated Sloper Antenna

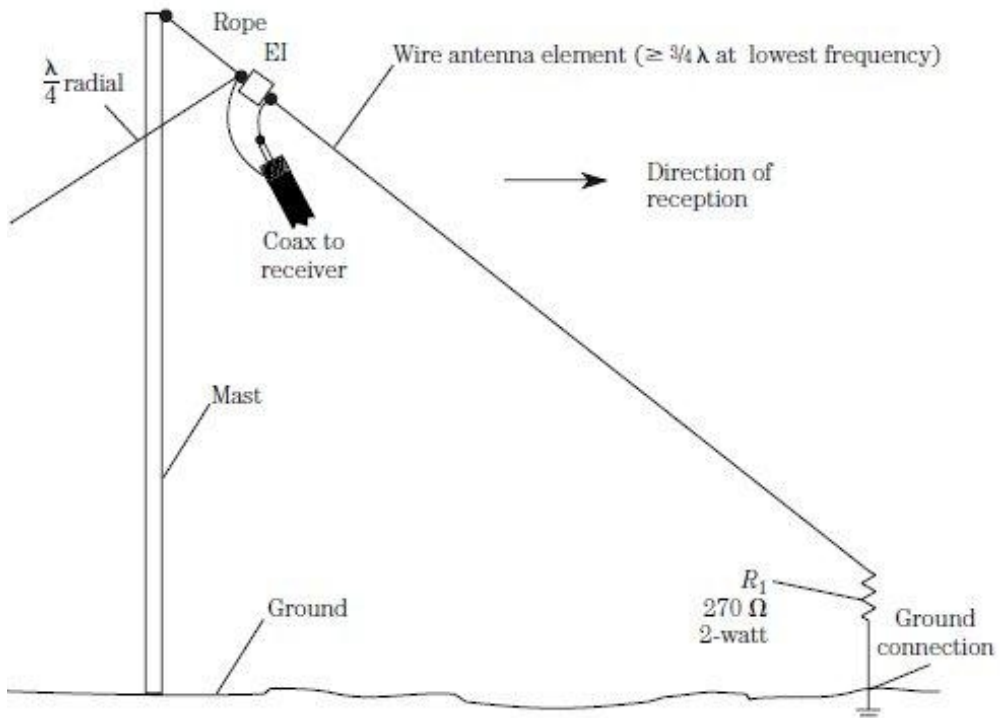

39. Double Extended Zepp Antenna

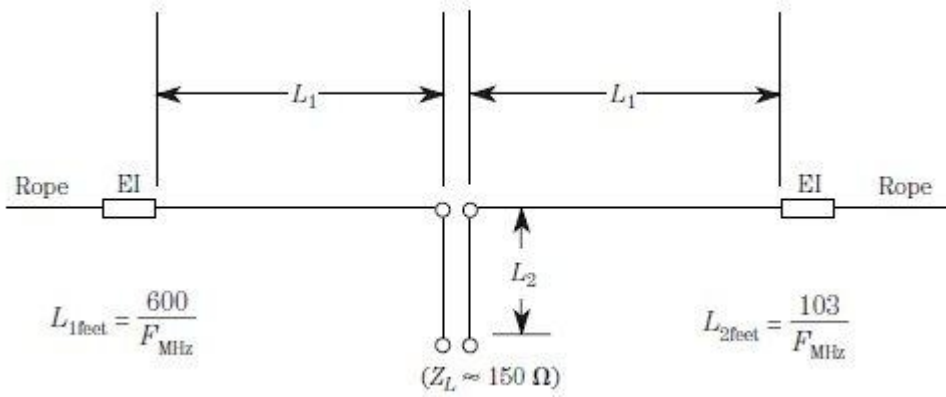

40. TCFTFD Dipole Antenna

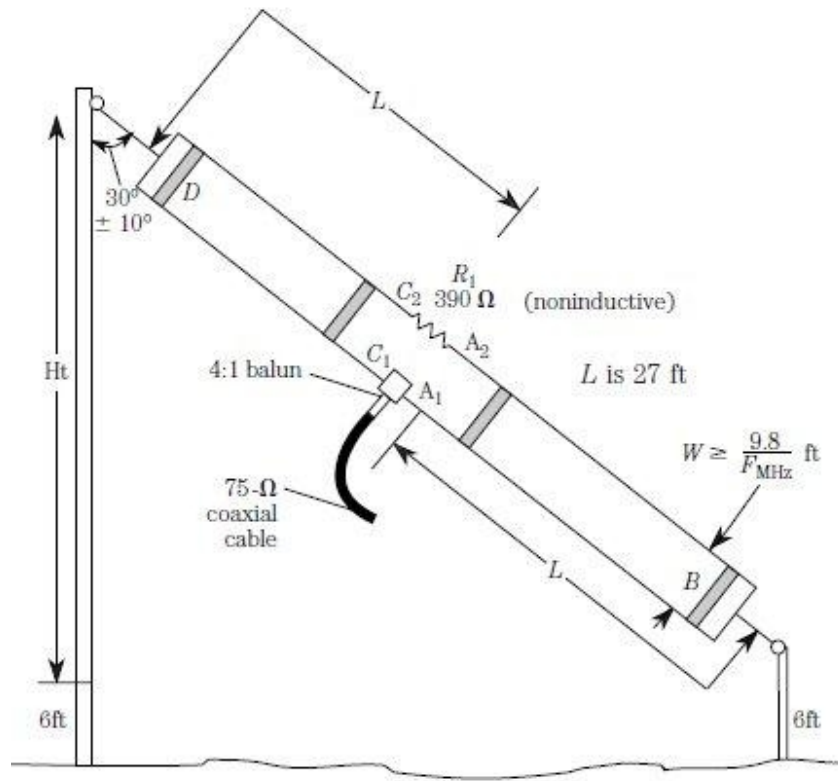

41. Vee-Sloper Antenna

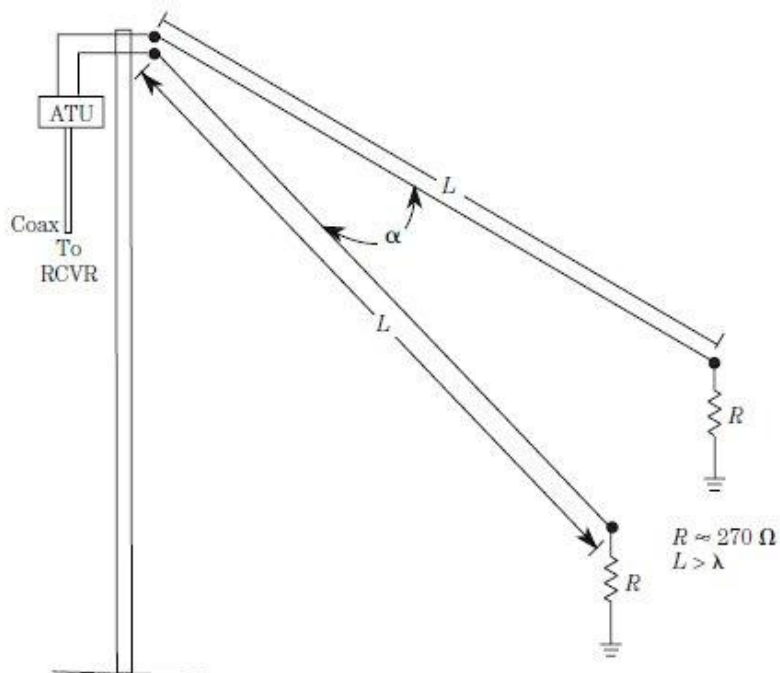

42. Rhombic Inverted-Vee Antenna

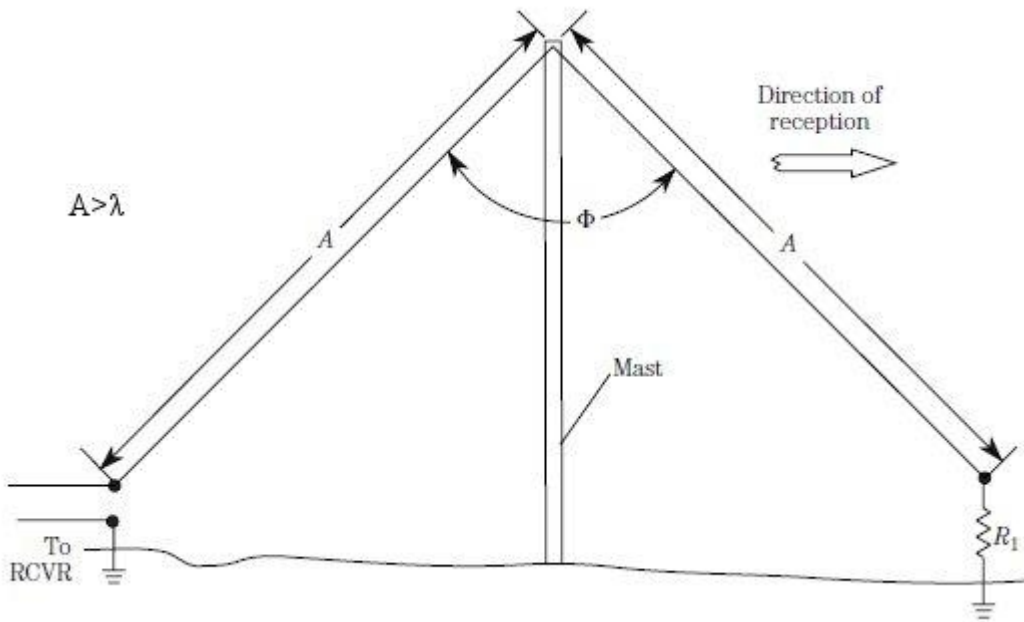

43. Counterpoise Longwire

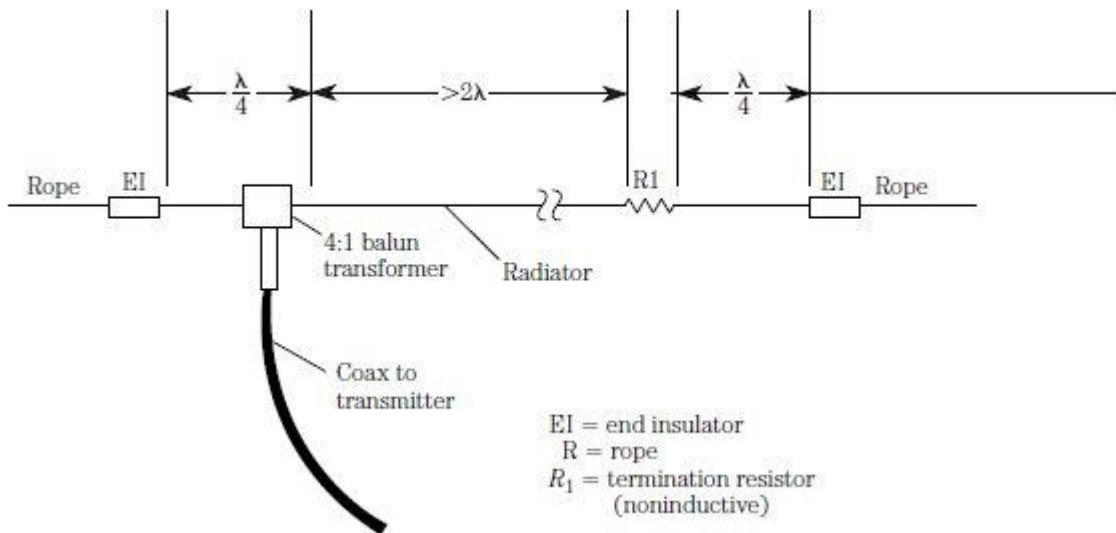

44. Bisquare Loop Antenna

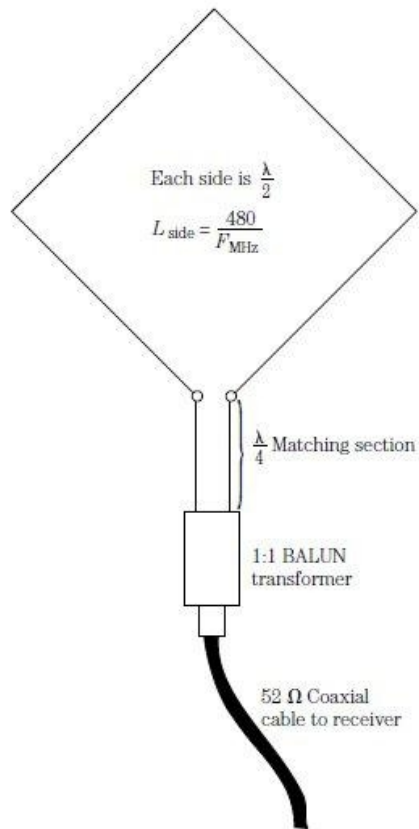

45. Piggyback Antenna for 10m

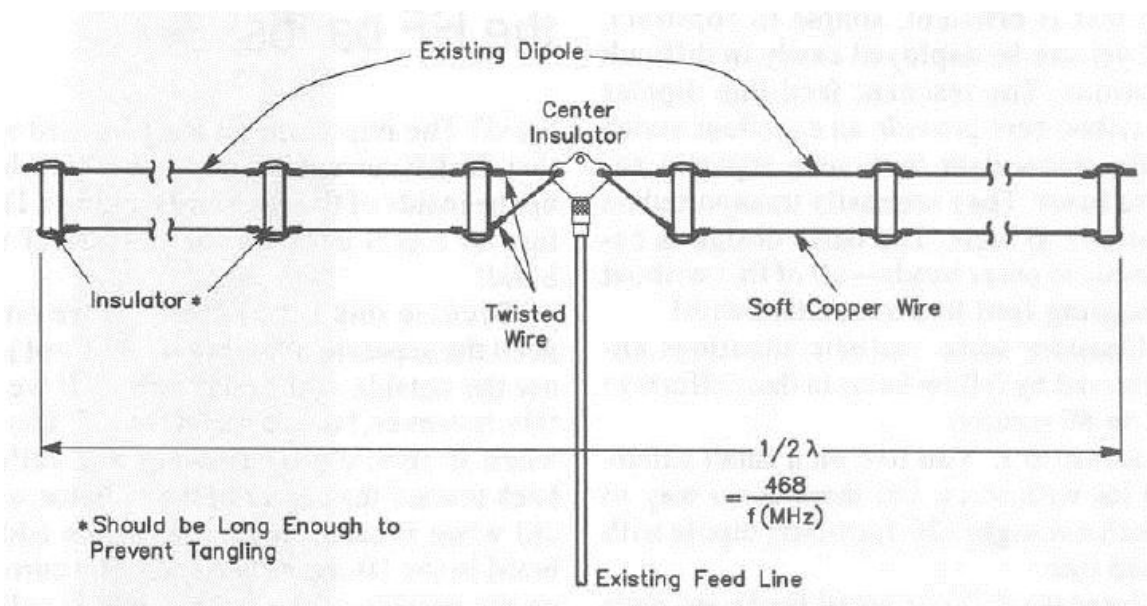

46. Vertical Sleeve Antenna for 10m

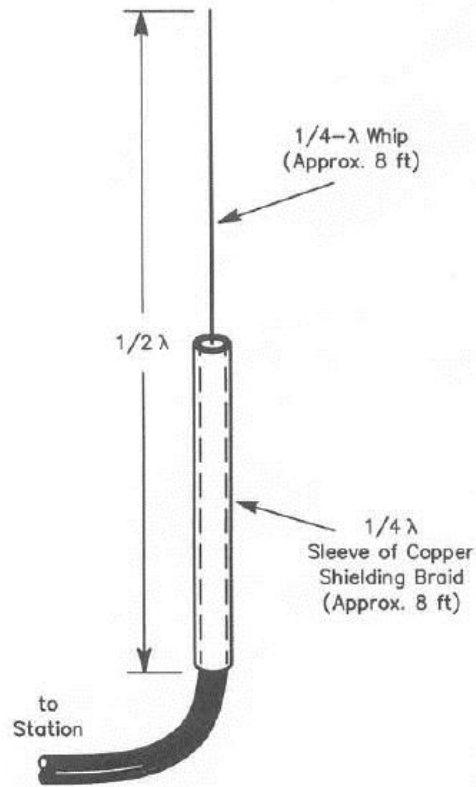

47. Double Windom Antenna

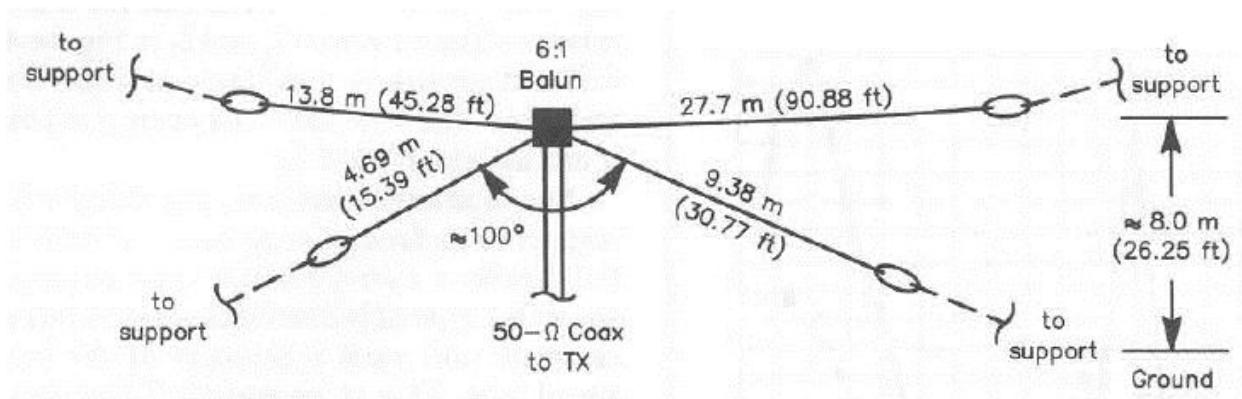

48. Double Windom for 9 Bands

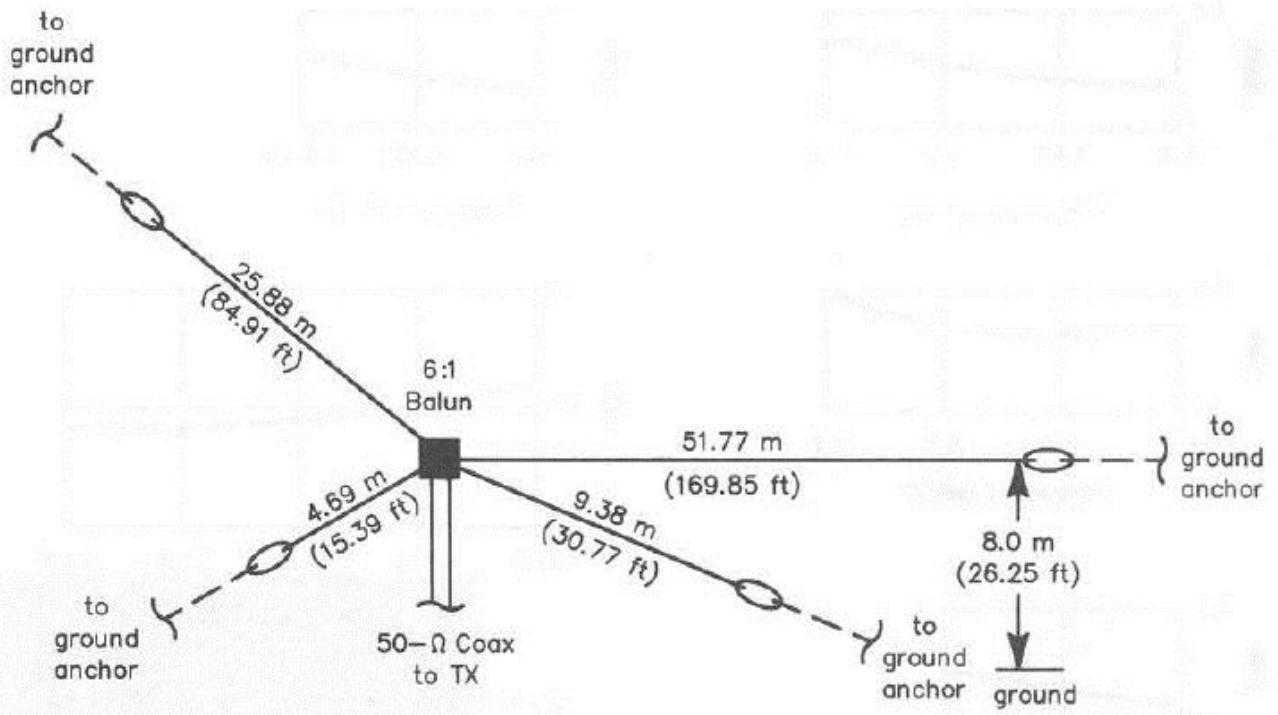

49. Collinear Trap Antenna

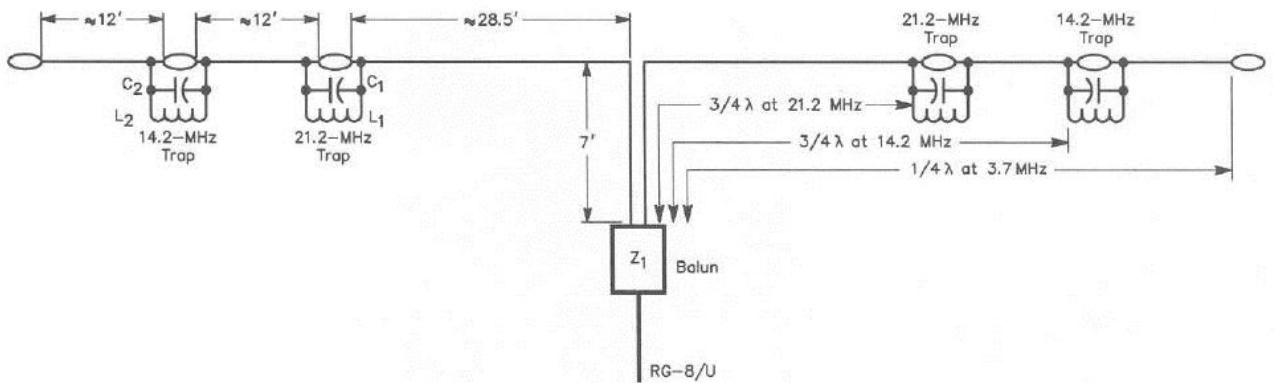

C1, C2—25-pf. 6000-volt disk ceramic. See text.
 L₁—Approx. 2 μH—4³/₄ turns No. 18, 2¹/₄-inches diam., ⁵/₈ inch long, or 5 turns No. 18, 2-inch diam., 16 tpi. See text.

L₂—Approx. 5 μH.—8 turns No. 18, 2¹/₄-inch dia., ⁵/₈ inch long, or 9 turns No. 18, 2-inch diam. 16 tpi. See text.
 Z₁—1 to 1 balun.

ANTENNAS

50. Short Dipole Antenna for 40m - 80m - 160m

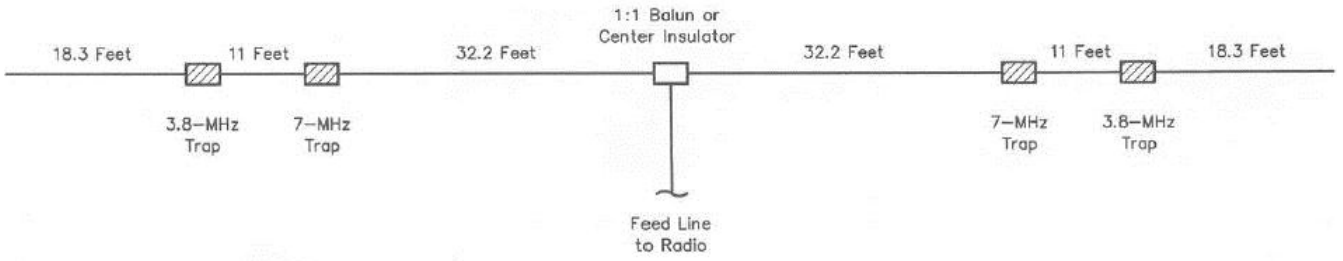

51. Center Fed-Zepp Antenna for 80m - 40m

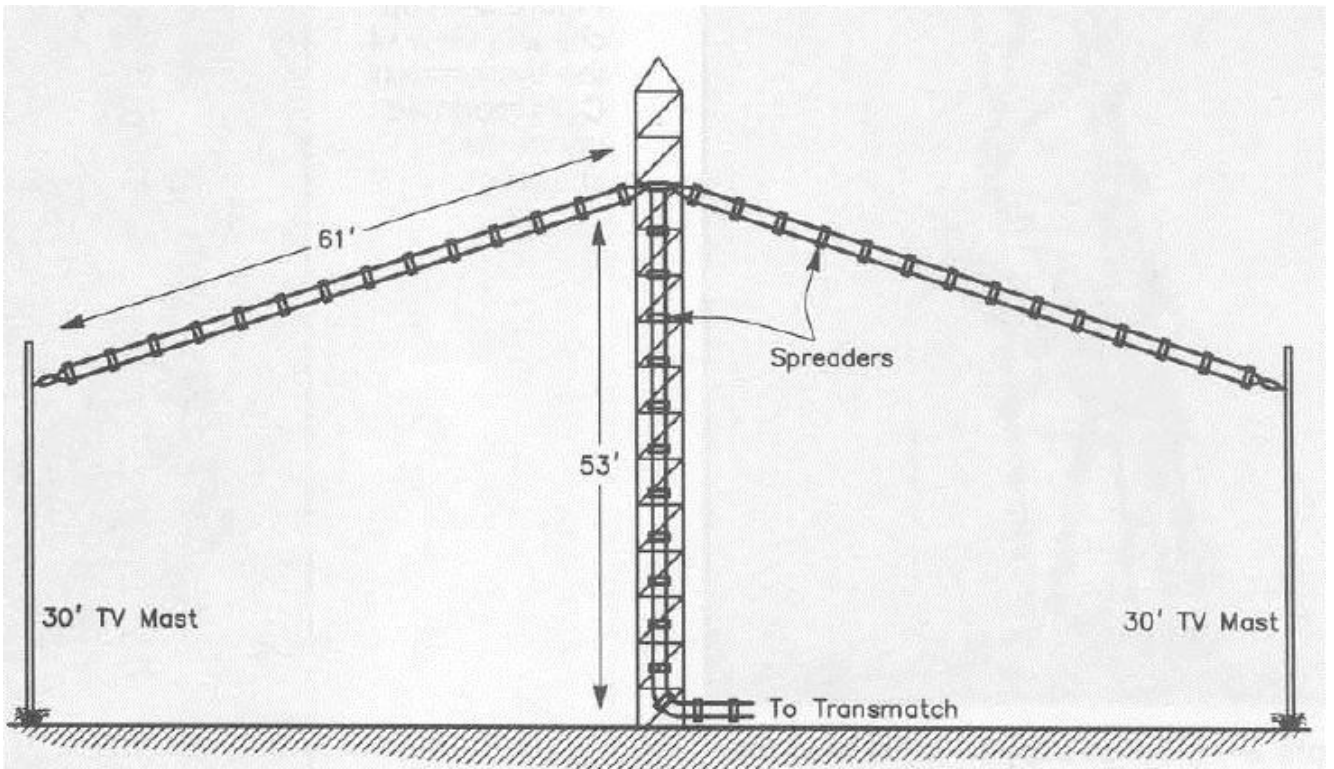

52. All-Bands Antenna

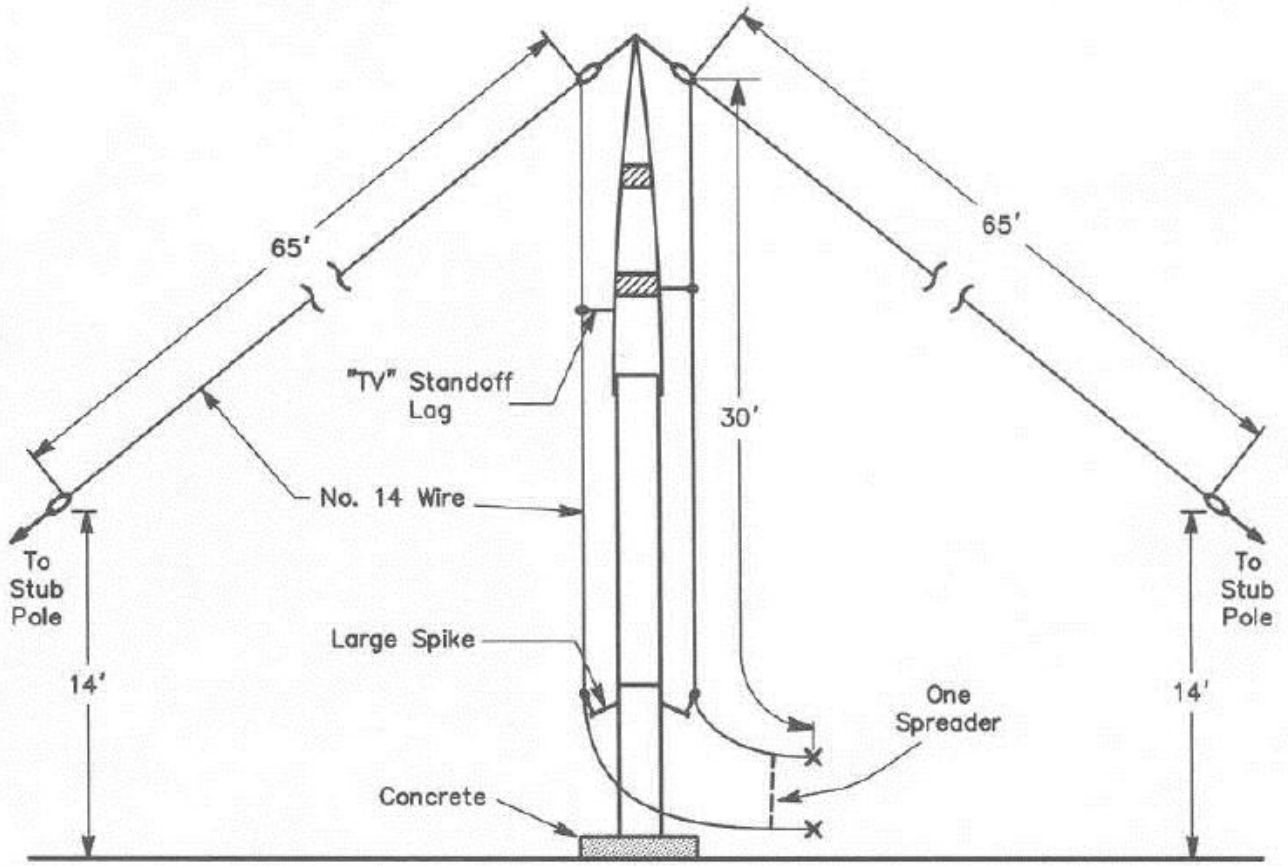

53. All-Bands Dipole Antenna

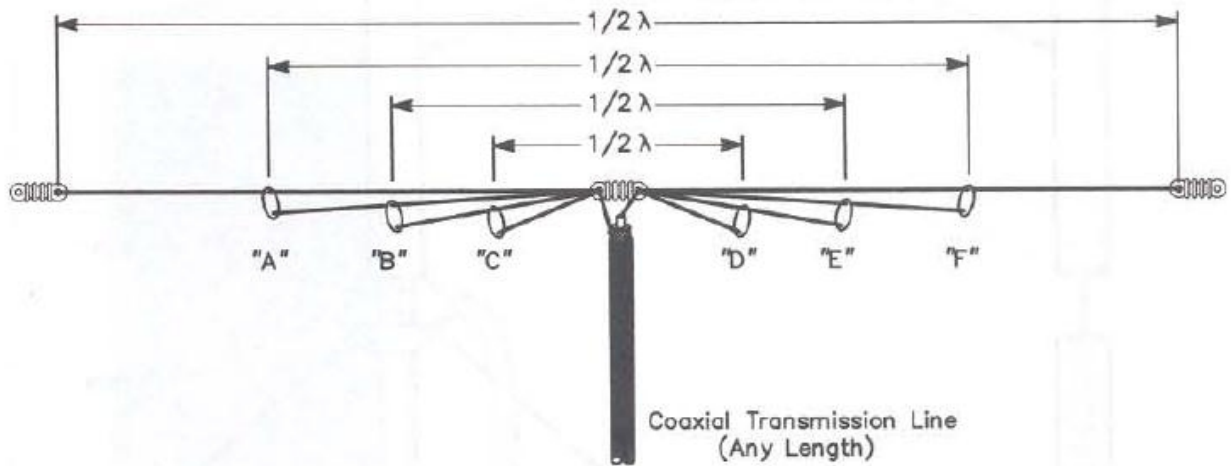

54. Multiband Z Antenna

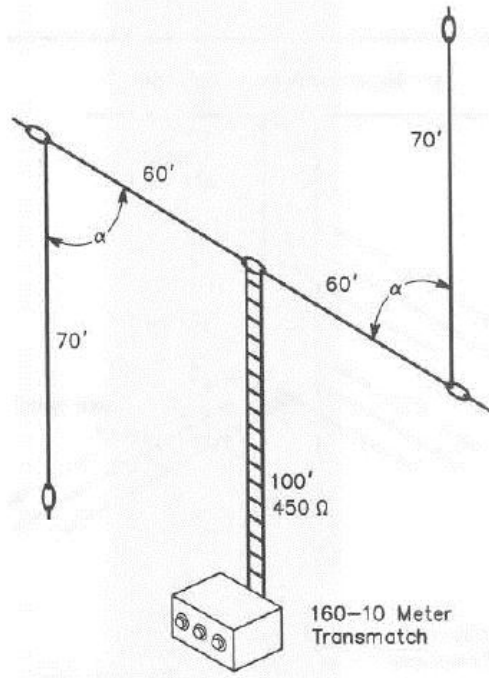

55. Multiband Dipole Antenna

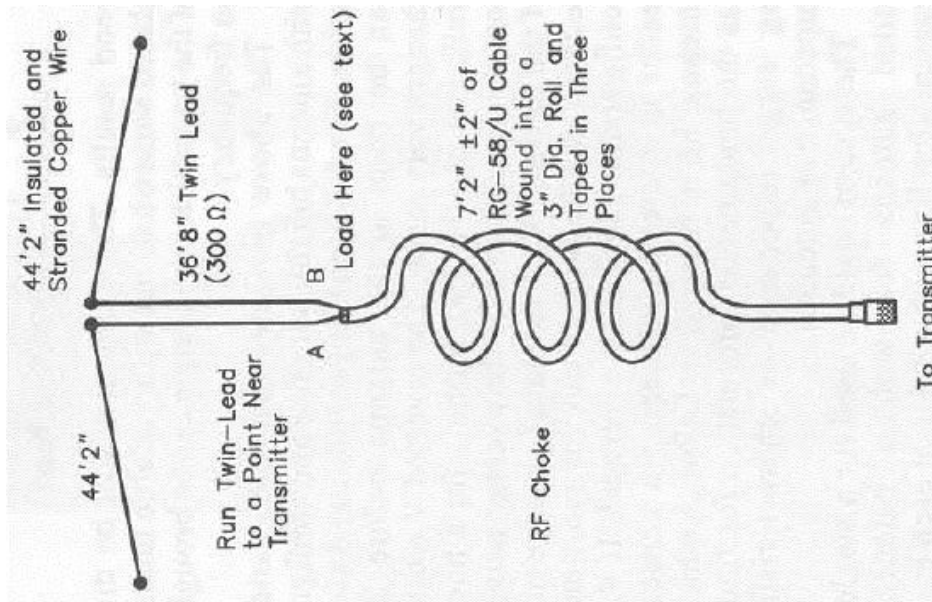

56. Five-Bands No-Tuner Antenna

ANTENNAS

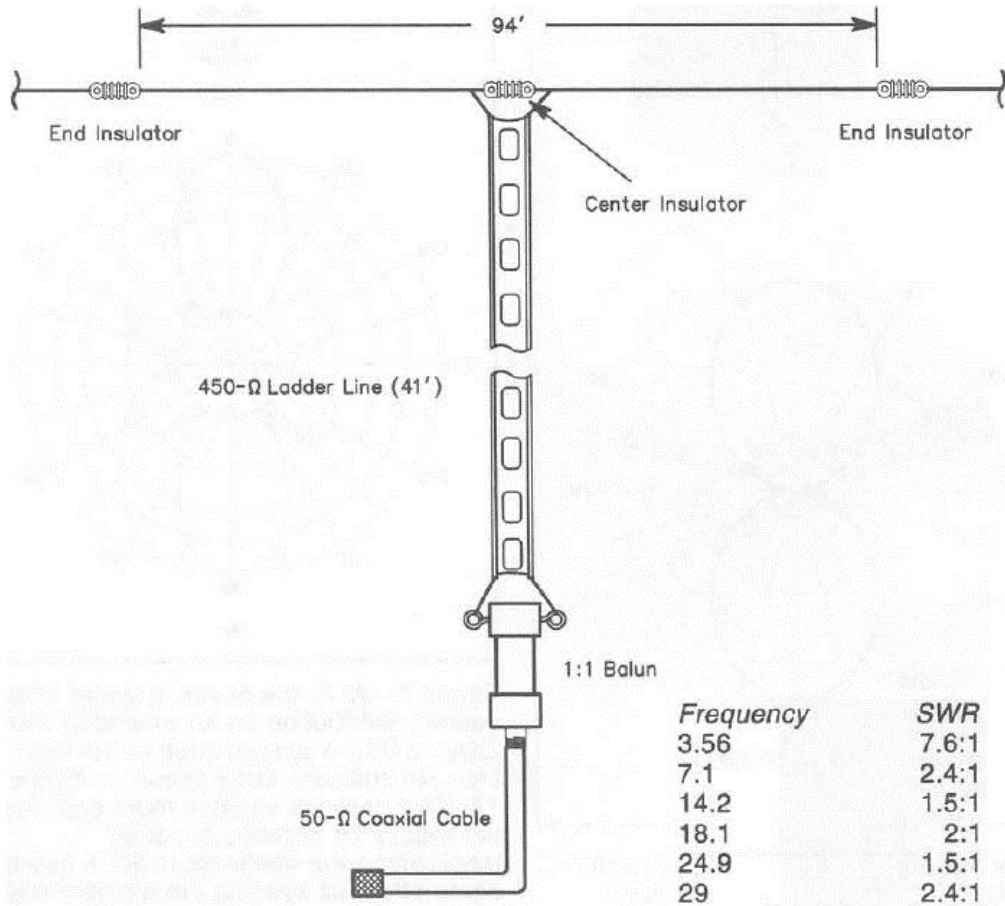

57. Dualband Full-wave Loop Antenna for 80m-40m

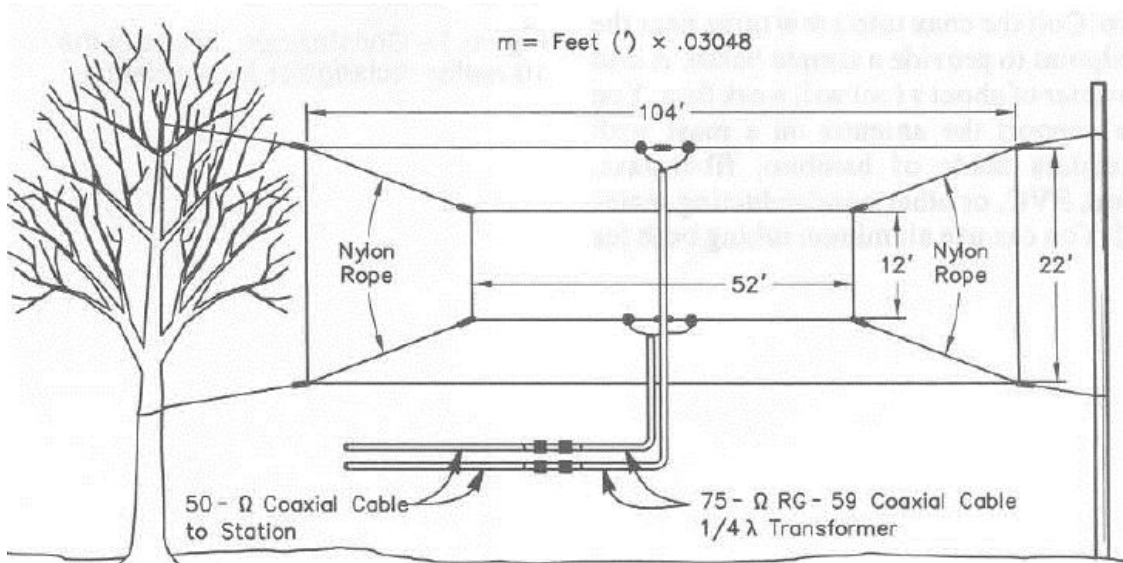

58. Loop Antenna for 10m

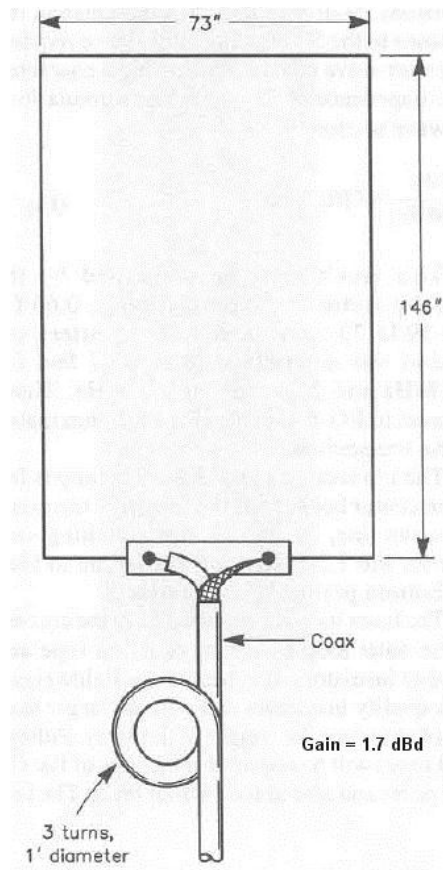

Lazy Quad Antenna for 10m

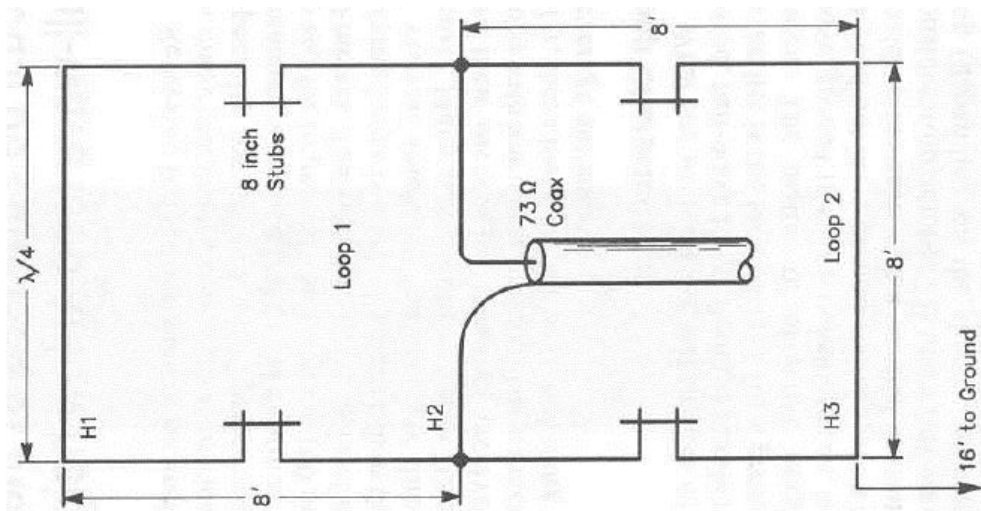

59. Tri-band Delta Loop Antenna for 80m - 40m - 30m

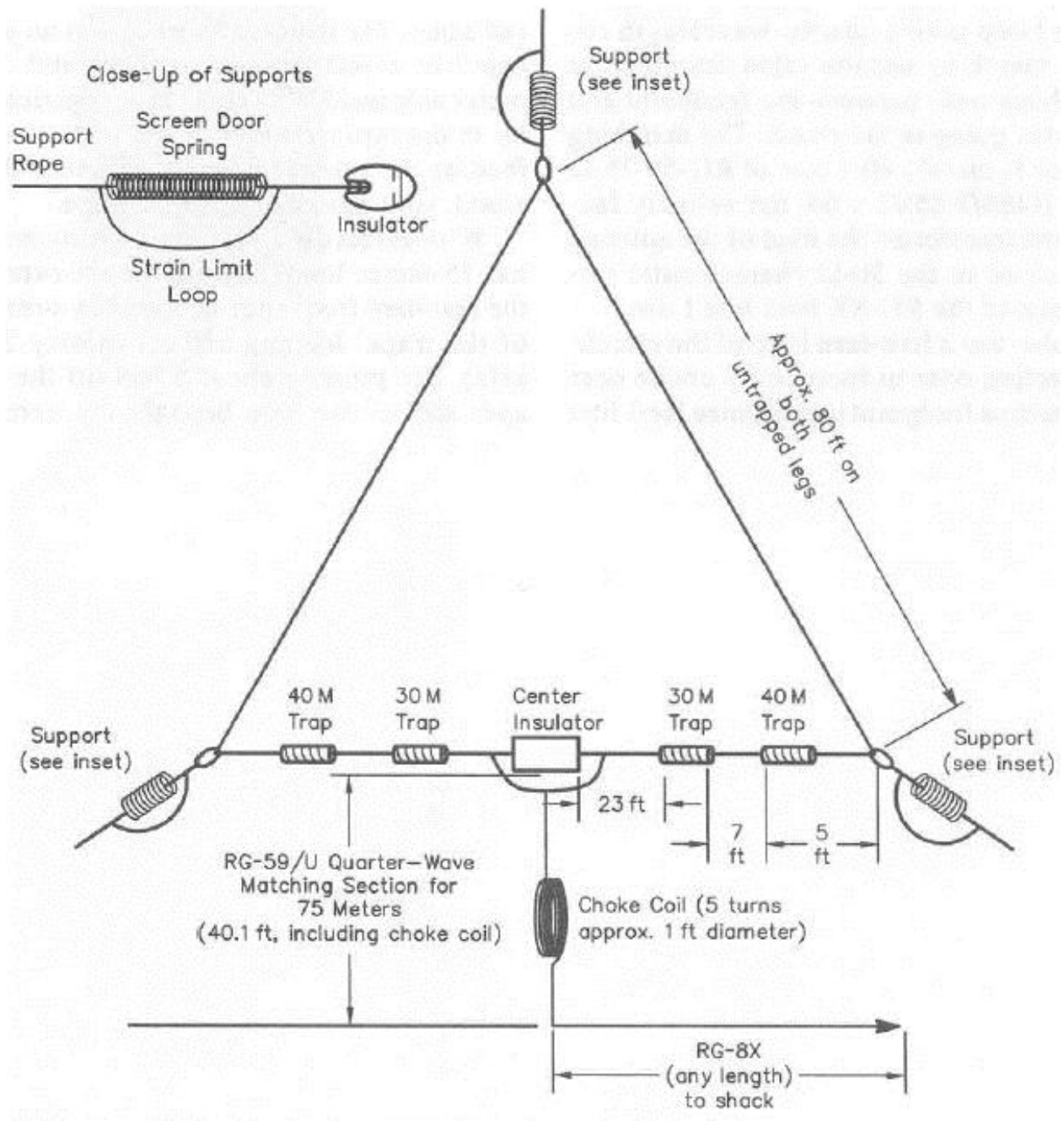

60. Dual-band Loop Antenna for 30m - 40m

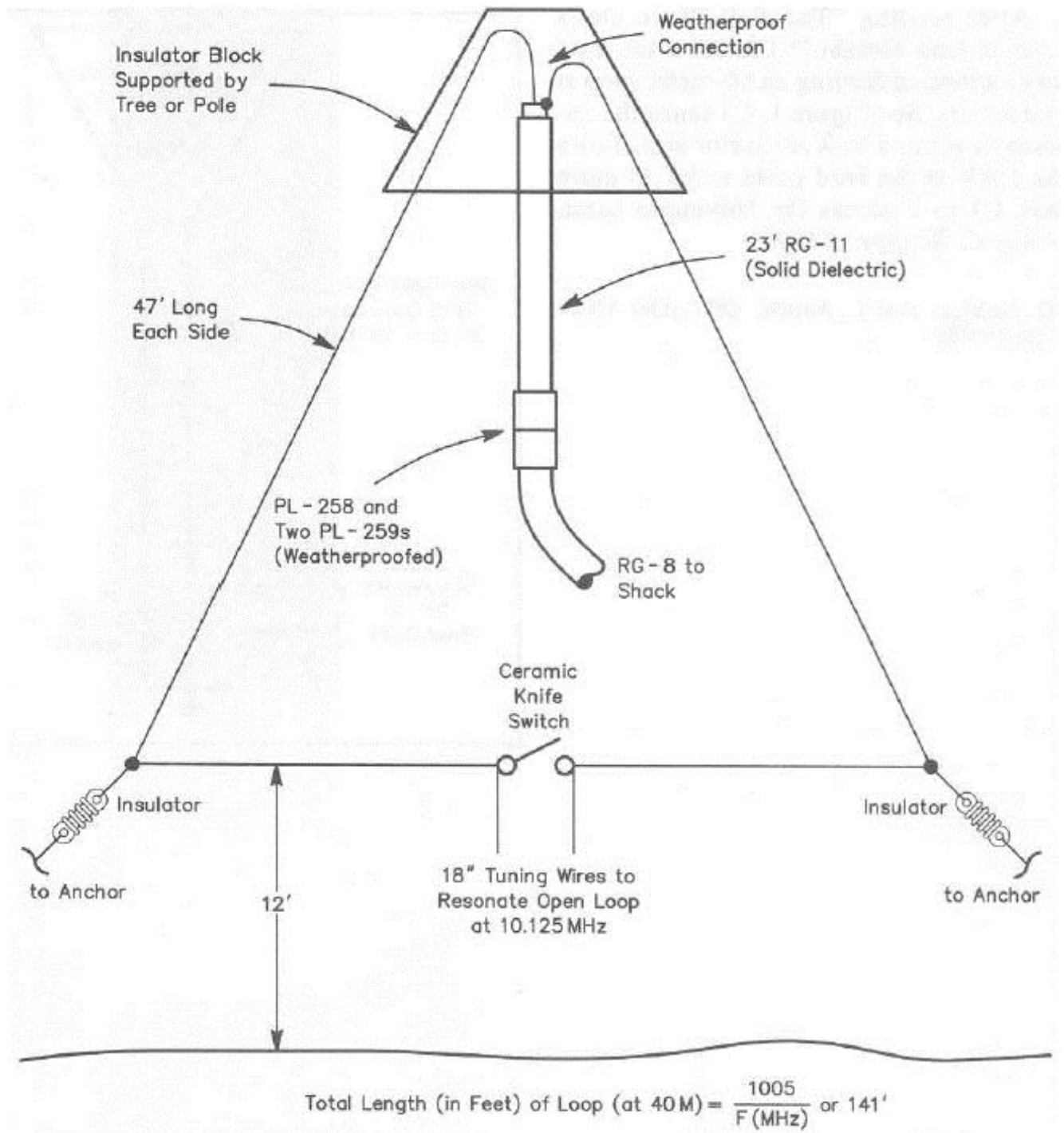

61. Wire-Beam Antenna for 80m

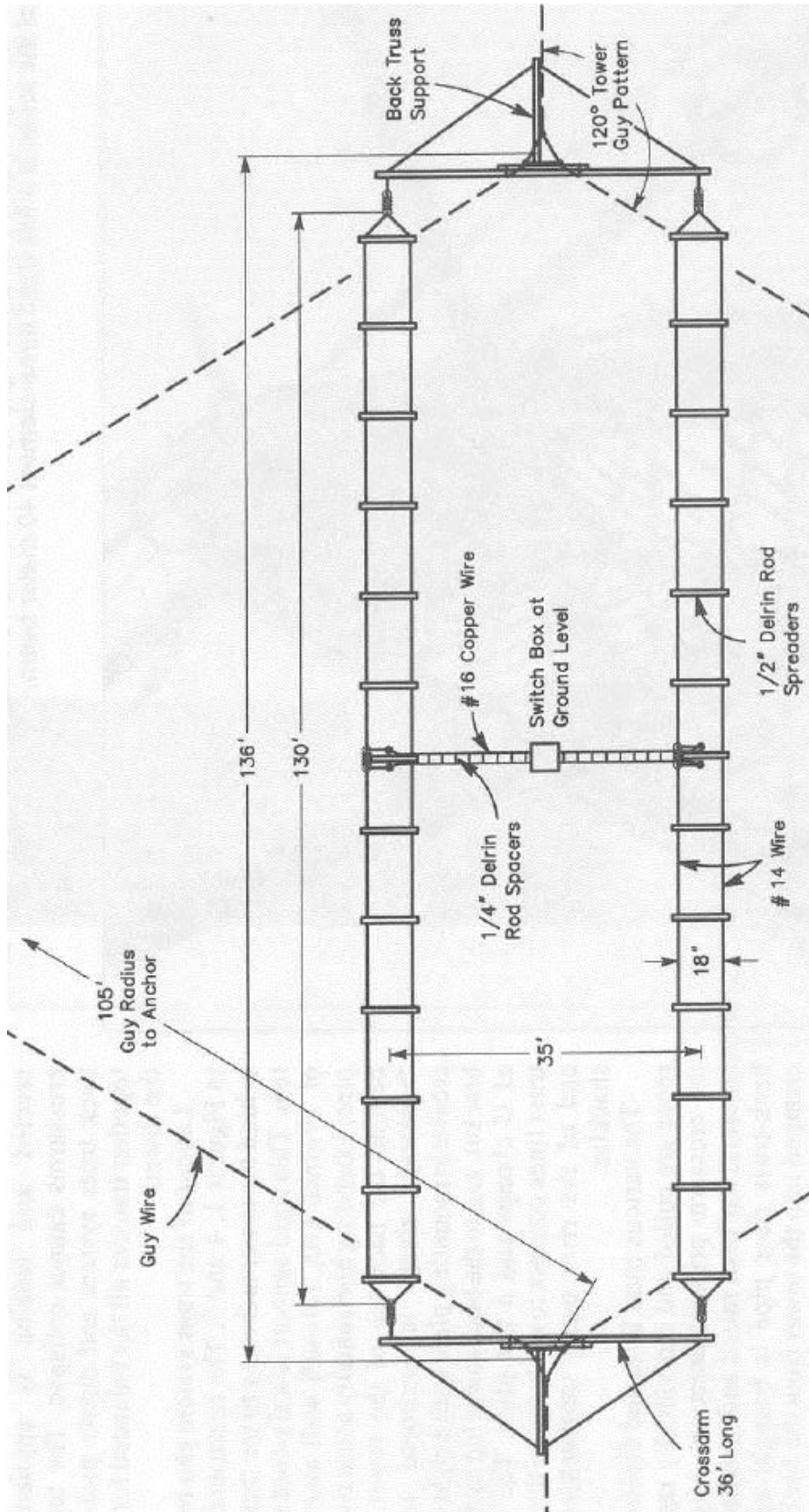

62. Dual-Band Sloper Antenna

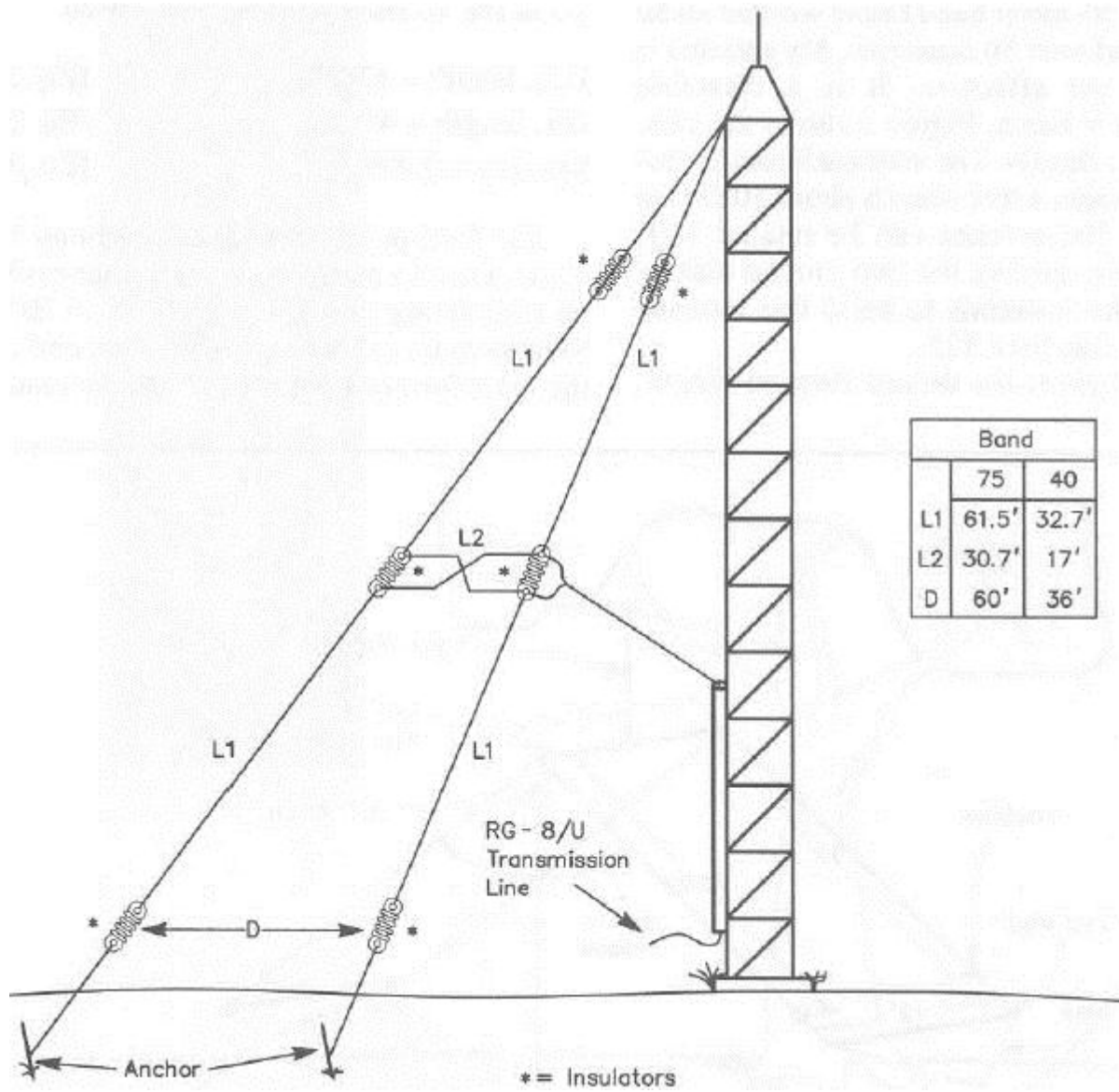

63. Inverted-V Beam Antenna for 30m

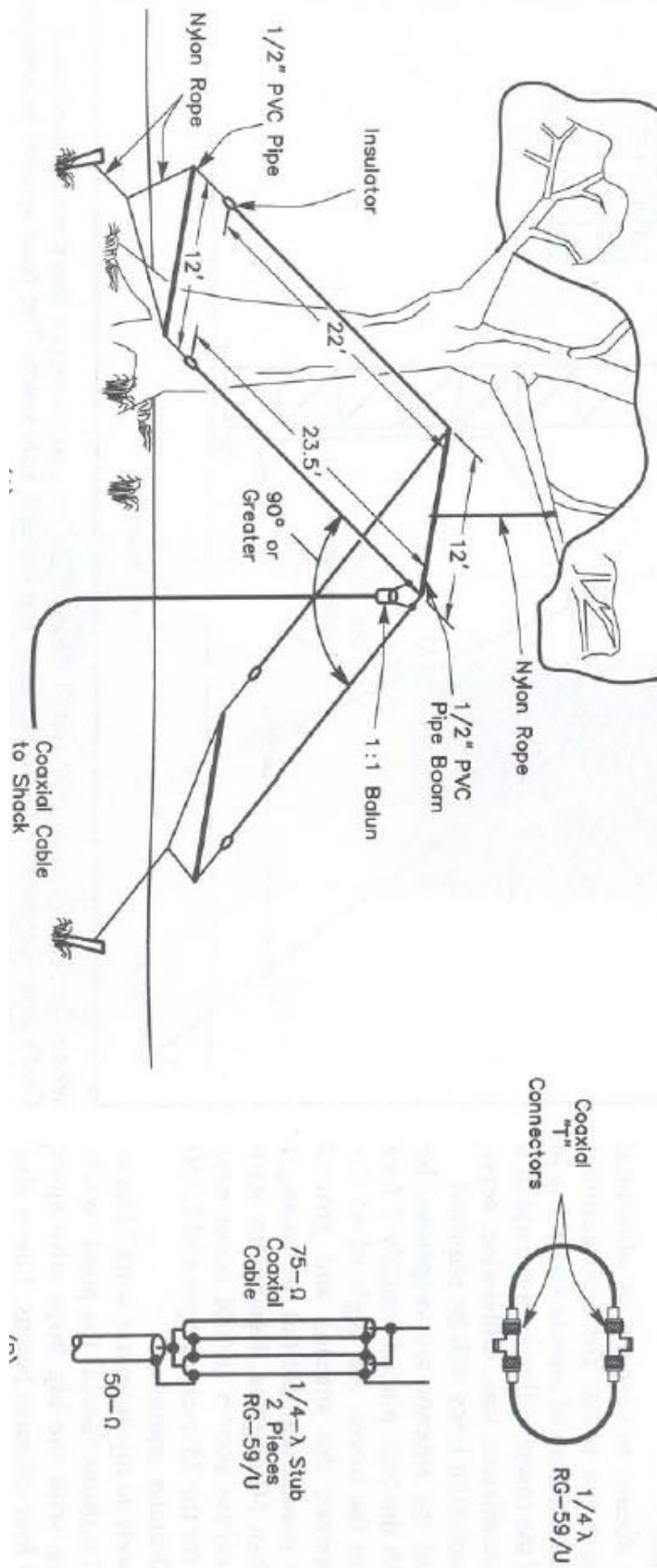

64. ZL-Special Beam Antenna for 15m

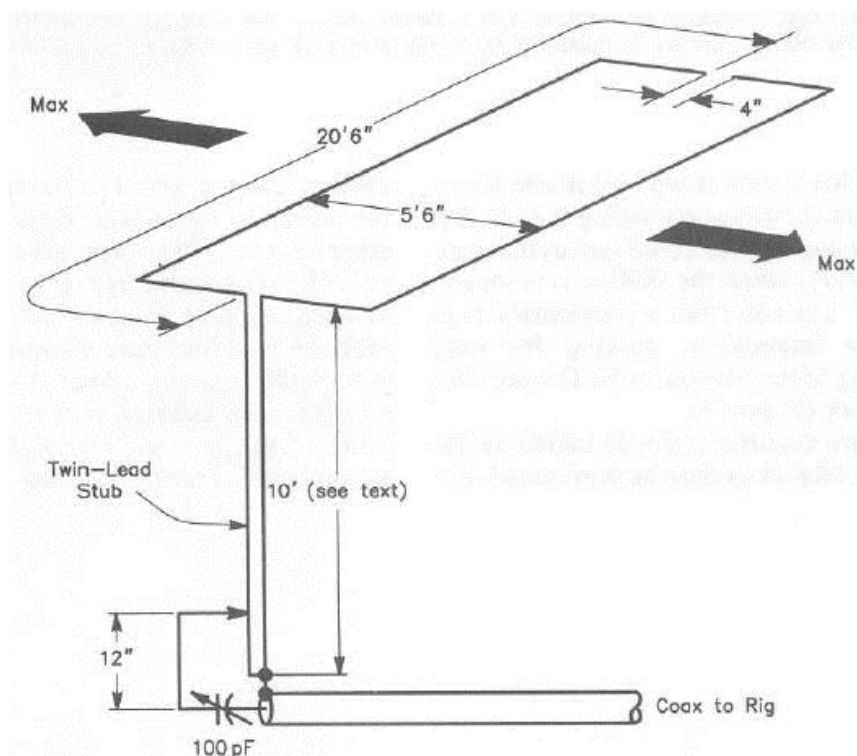

65. Half-Sloper Antenna for 160m

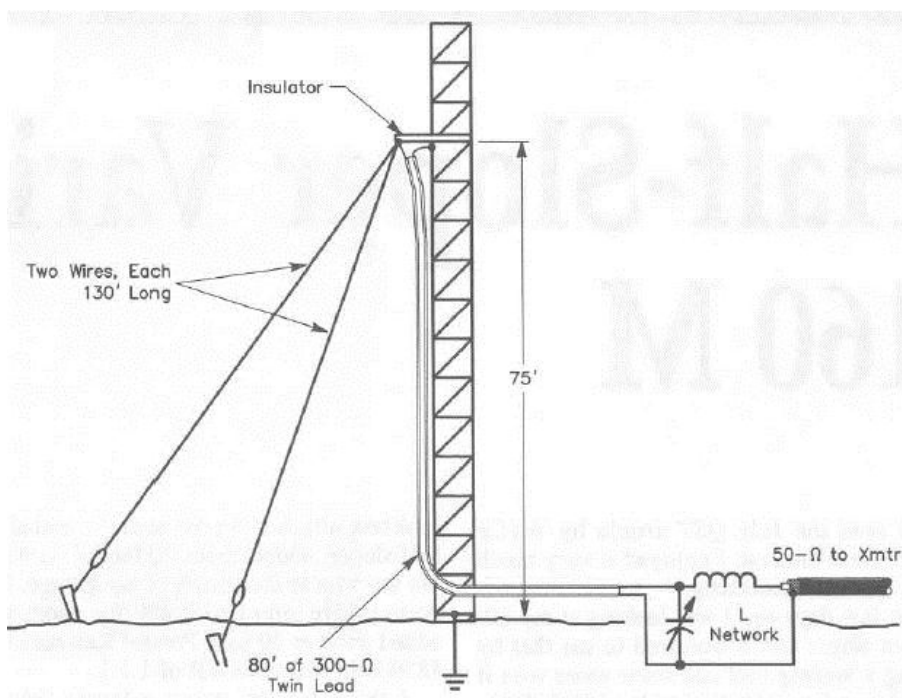

66. Two-Bands Half Sloper for 80m - 40m

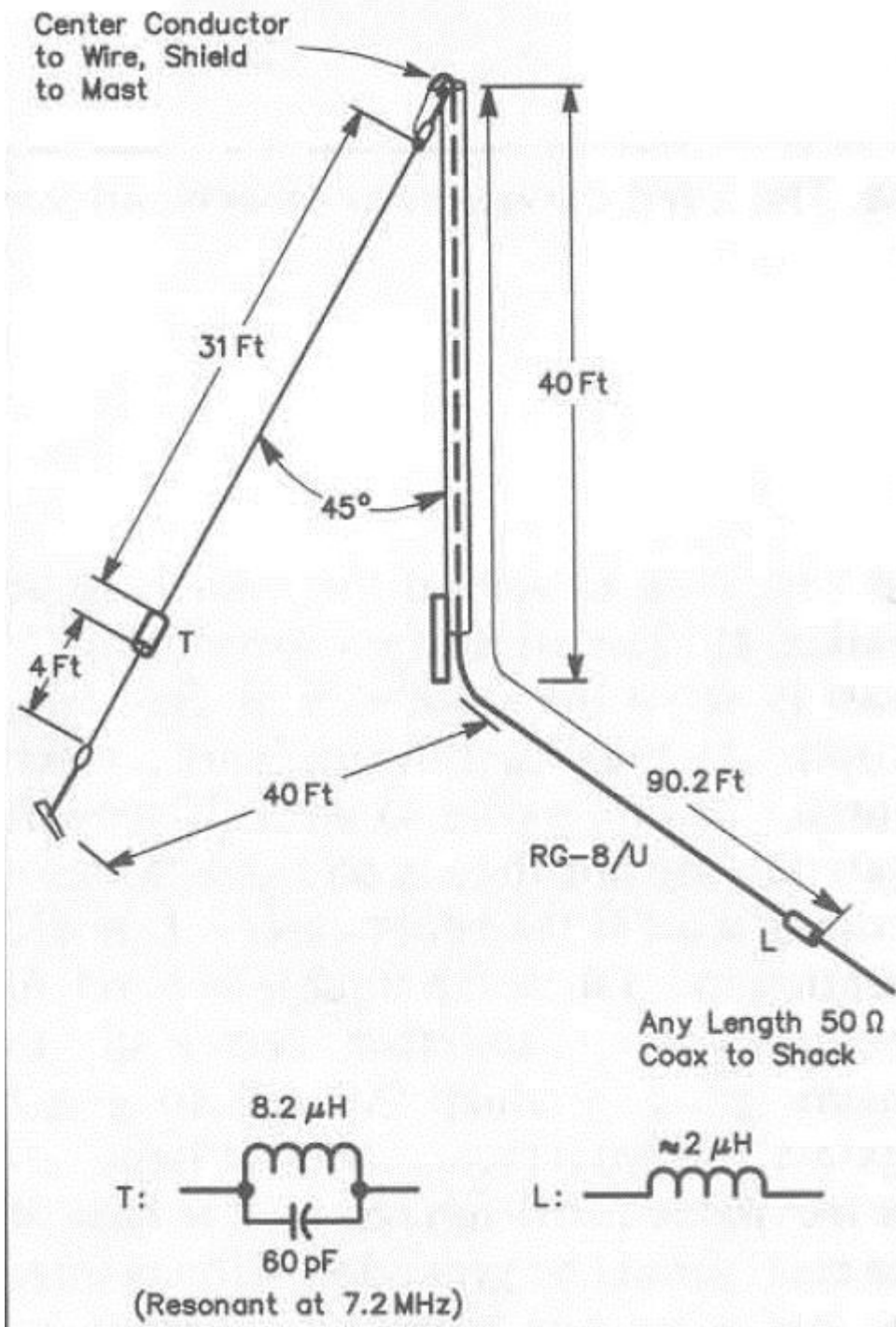

67. Linear Loaded Sloper Antenna for 160m

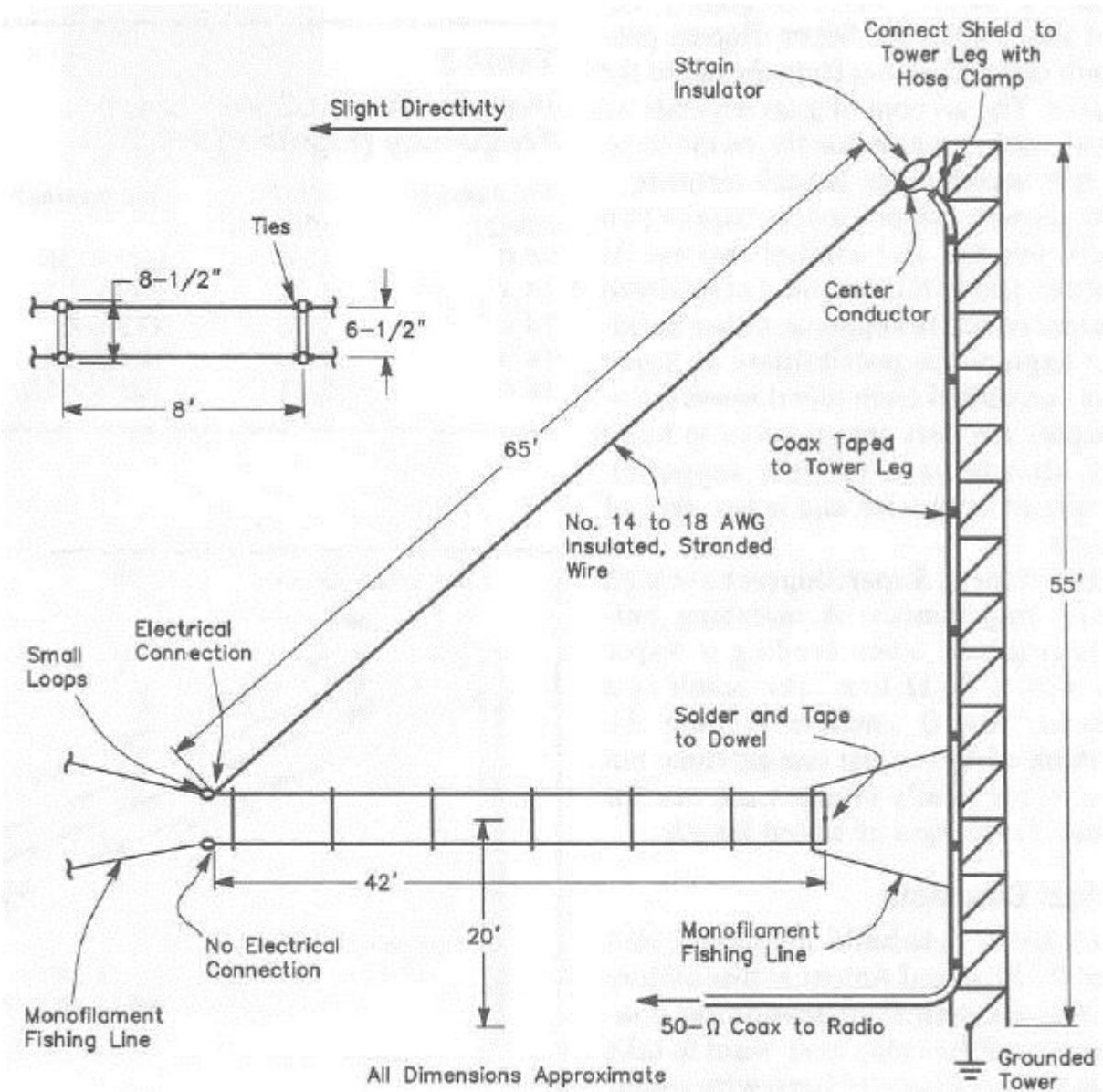

68. Super-Sloper Antenna

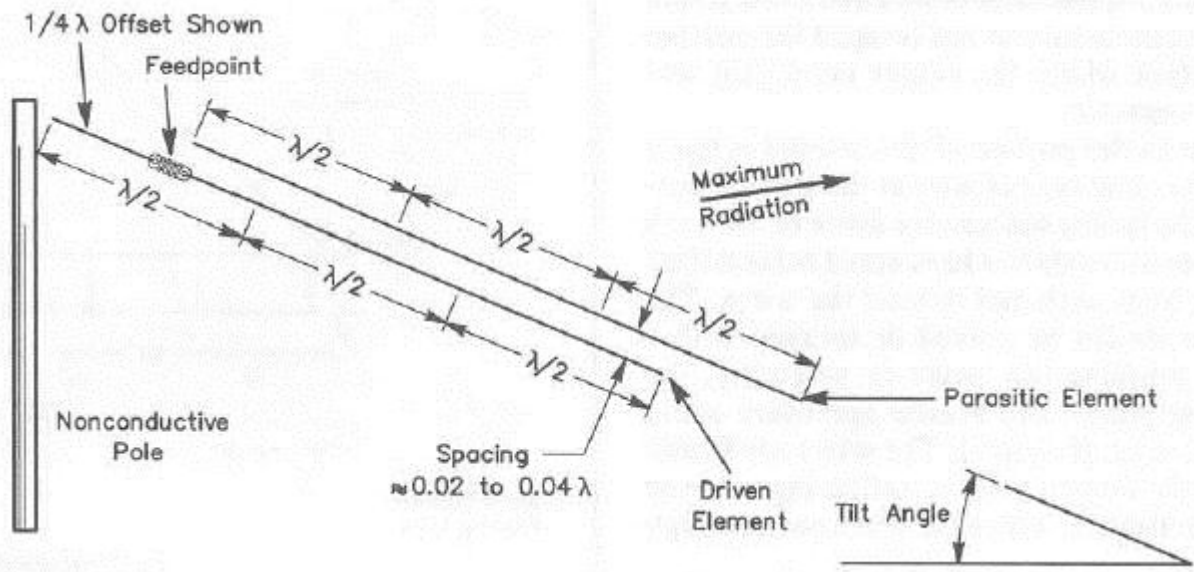

69. Tower Pole as a Vertical Antenna for 80m

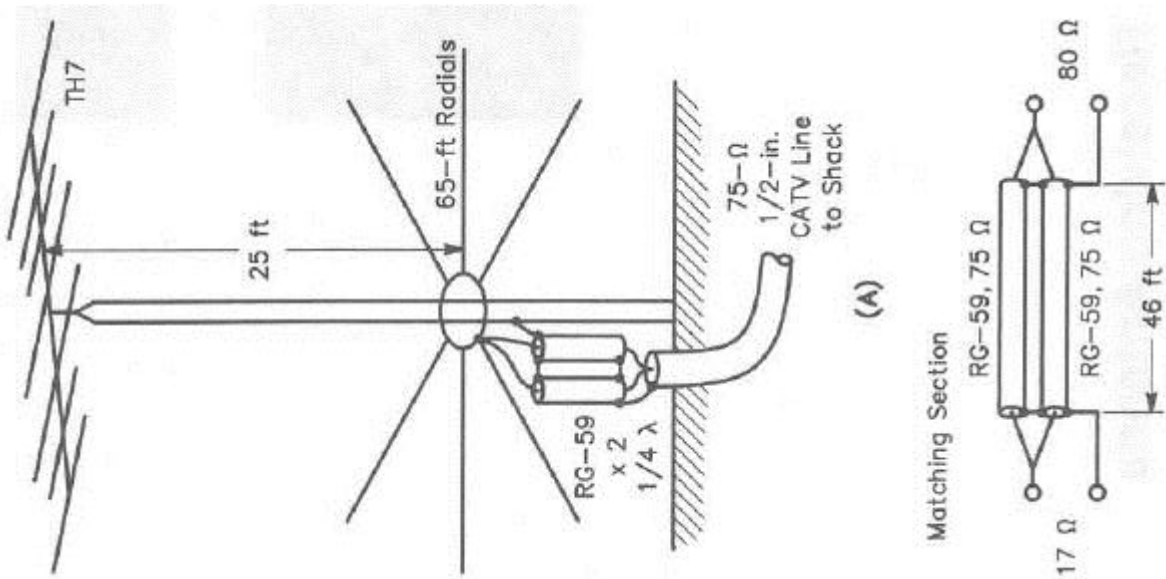

70. Clothesline Antenna

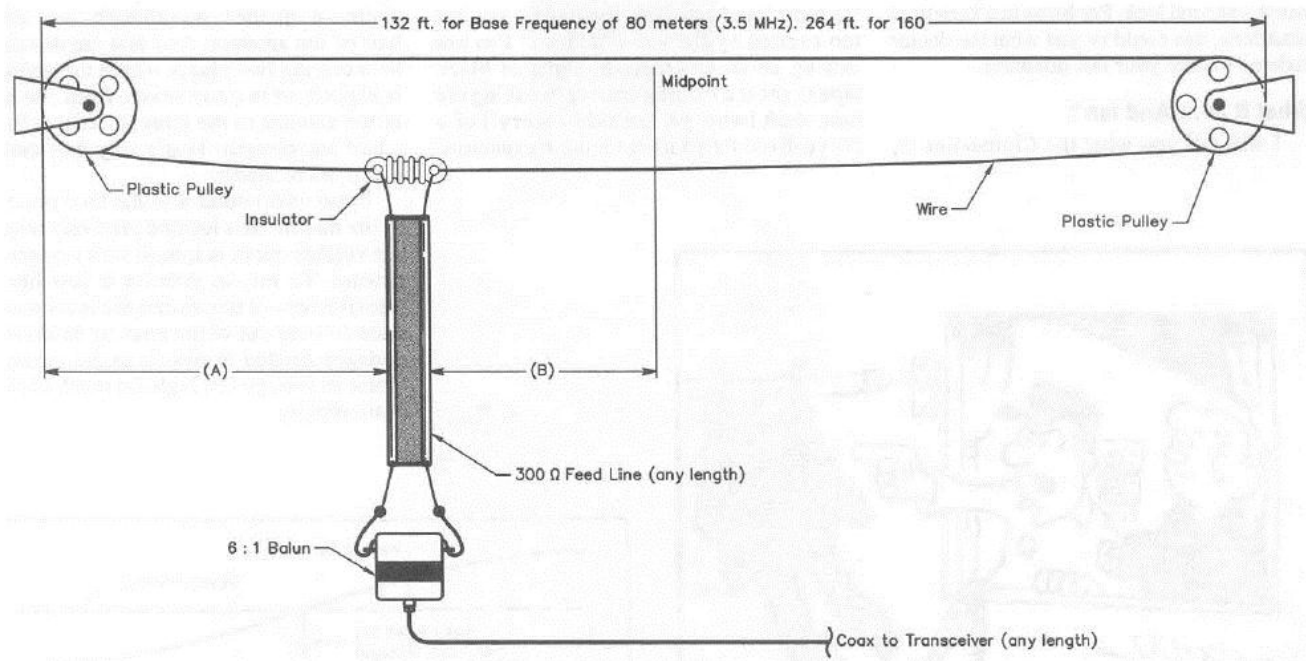

References:

- Antenna Toolkit - J. Carr
- Practical Antenna Handbook - J. Carr
- More Antenna Classics - C. Hutchinson
- ARRL Antenna Handbook 1990-2007
- ARRL Handbook 1990-2009
- ARRL Antenna Compendium